

USER'S MANUAL

eBOX570 Series

Embedded System

User's Manual



www.axiomtek.com

Disclaimers

This manual has been carefully checked and believed to contain accurate information. Axiomtek Co., Ltd. assumes no responsibility for any infringements of patents or any third party's rights, or any liability arising from such uses.

Axiomtek does not warrant or assume any legal liability or responsibility for the accuracy, completeness or usefulness of any information in this document. Axiomtek does not make any commitment to update any information in this manual.

Axiomtek reserves the right to change or revise this document and/or product at any time without notice.

No part of this document may be reproduced, stored in a retrieval system, or transmitted in any forms or by any means, electronic, mechanical, photocopying, recording, among others, without prior written permissions of Axiomtek Co., Ltd.

©Copyright 2024 Axiomtek Co., Ltd.

All Rights Reserved

March 2024, Version A1

Printed in Taiwan

Safety Precautions

Before getting started, please read the following important safety precautions.

1. The eBOX570 does not come with an operating system which must be loaded first before installation of any software into the computer.
2. Be sure to ground yourself to prevent static charge when installing any internal components. Use a wrist grounding strap and place all electronic components in any static-shielded devices. Most electronic components are sensitive to static electrical charge.
3. Disconnect the power cord from the eBOX570 prior to making any installation. Be sure both the system and all external devices are turned OFF. Sudden surge of power could ruin sensitive components. Make sure the eBOX570 is properly grounded.
4. Make sure the voltage of the power source is correct before connecting it to any power outlet.
5. Turn Off system power before cleaning. Clean the system using a cloth only. Do not spray any liquid cleaner directly onto the screen.
6. Do not leave equipment in an uncontrolled environment where the storage temperature is below -40°C or above 80°C as it may damage the equipment.
7. Do not open the system's back cover. If opening the cover for maintenance is a must, only a trained technician is allowed to do so. Integrated circuits on computer boards are sensitive to static electricity. To avoid damaging chips from electrostatic discharge, observe the following precautions:
 - Before handling a board or integrated circuit, touch an unpainted portion of the system unit chassis for a few seconds. This will help discharge any static electricity on human body.
 - When handling boards and components, wear a wrist grounding strap available from most electronic component stores.
8. Caution:

Risk of explosion if battery is replaced by an incorrect type Dispose of used batteries according to the instructions.

IL Y A RISQUE D'EXPLOSION SI LA BATTERIE EST
REPLACEE
PER UNE BATTERIE DE TYPE INCORRECT.
METTRE AU REBUT LES BATTERIES USAGEES
CONFORMEMENT AUX INSTRUCTIONS
9. Warning:

Hot Surface Do Not Touch.

Restricted access locations: The equipment should only be installed in a Restricted Access Area.

Classifications

1. Degree of protection against electric shock: not classified
2. Degree of protection against ingress of water: IP40
3. Equipment not suitable for use in the presence of a flammable anesthetic mixture with air, oxygen or nitrous oxide.
4. Mode of operation: Continuous

General Cleaning Tips

Please keep the following precautions in mind while understanding the details fully before and during any cleaning of the computer and any components within.

A piece of dry cloth is ideal to clean the device.

1. Be cautious of any tiny removable components when using a vacuum cleaner to absorb dirt on the floor.
2. Turn the system off before cleaning up the computer or any components within.
3. Avoid dropping any components inside the computer or getting circuit board damp or wet.
4. For cleaning, be cautious of all kinds of cleaning solvents or chemicals which may cause allergy to certain individuals.
5. Keep foods, drinks or cigarettes away from the computer.

Cleaning Tools:

Although many companies have created products to help improve the process of cleaning computer and peripherals, users can also use house hold items accordingly for cleaning. Listed below are items available for cleaning computer or computer peripherals.

Pay special attention to components requiring designated products for cleaning as mentioned below.

- Cloth: A piece of cloth is the best tool to use when rubbing up a component. Although paper towels or tissues can be used on most hardware as well, it is recommended to use a piece of cloth.
- Water or rubbing alcohol: A piece of cloth may be somewhat moistened with water or rubbing alcohol before being rubbed on the computer. Unknown solvents may be harmful to plastic parts.
- Absorb dust, dirt, hair, cigarette and other particles outside of a computer can be one of the best methods of cleaning a computer. Over time these items may restrict the airflow in a computer and cause circuitry to corrode.
- Cotton swabs: Cotton swaps moistened with rubbing alcohol or water are applicable to reach areas in keyboard, mouse and other areas.
- Foam swabs: If possible, it is better to use lint free swabs such as foam swabs.



【Note】 : *It is strongly recommended that customer should shut down the system before starting to clean any single components.*

Please follow the steps below:

1. Close all application programs.
2. Close operating software.
3. Turn off power switch.
4. Remove all devices.
5. Pull out power cable.

Scrap Computer Recycling

Please inform the nearest Axiomtek distributor as soon as possible for suitable solutions in case computers require maintenance or repair; or for recycling in case computers are out of order.

Trademarks Acknowledgments

Axiomtek is a trademark of Axiomtek Co., Ltd.

IBM, PC/AT, PS/2, VGA are trademarks of International Business Machines Corporation. Intel® and Pentium® are registered trademarks of Intel Corporation.

MS-DOS, Microsoft C and QuickBasic, Windows 10, Windows 8.1, Windows 8, Windows 7, Windows XPE, Windows XP, Windows CE embedded, Linux are trademarks of Microsoft Corporation.

Other brand names and trademarks are the properties and registered brands of their respective owners.

Table of Contents

Disclaimers.....	ii
Safety Precautions.....	iii
Classifications.....	iv
General Cleaning Tips	v
Scrap Computer Recycling.....	vi
SECTION 1 INTRODUCTION.....	1
1.1 General Descriptions	1
1.2 System Specifications	3
1.2.1 CPU	3
1.2.2 I/O System	3
1.2.3 System Specifications.....	4
1.2.4 Driver CD Contents	5
1.3 Dimensions	6
1.3.1 System Dimensions.....	6
1.3.2 Wall-mount Bracket Dimensions	7
1.3.3 Din-Rail Bracket Dimensions.....	9
1.3.4 VESA Mount Bracket Dimensions	11
1.4 I/O Outlets.....	13
1.5 Packing List.....	14
1.6 Model List	14
SECTION 2 HARDWARE INSTALLATION	15
2.1 Installation of DRAM Module.....	15
2.2 Installation of Mini PCIe Module (CN11)	16
2.3 Installation of M.2 Key E Mini PCIe Module (CN3)	19
2.4 Installation of NVMe SSD Module (CN10).....	21
SECTION 3 JUMPER & CONNECTOR SETTINGS.....	23
3.1 Locations of Jumpers & Connectors.....	23
3.2 Clear CMOS Setting	25
3.2.1 Clear CMOS (SW1).....	25
3.3 Connectors	26
3.3.1 DC-in Phoenix Power Connector (CN1).....	27
3.3.2 HDMI Connector (CN12, CN13).....	27
3.3.3 Serial Port Connector (CN4,CN5).....	28
3.3.4 USB 3.2 Connector (CN15, CN16, CN17) / USB 2.0 Connector (CN18) .	29
3.3.5 Ethernet Connector (LAN1~LAN2).....	30
3.3.6 ATX Power button.....	30
3.3.7 Reset Switch.....	30
3.3.8 Remote Power Switch	31
3.3.9 SIM Card Slots (CN9).....	31
3.3.10 Full-Size PCI Express Mini Card Slot (CN11).....	31
3.3.11 M.2 2230 Key E slot (CN3)	32
3.3.12 M.2 2280 Key M slot (CN10).....	34
SECTION 4 BIOS SETUP UTILITY	35
4.1 Starting	35
4.2 Navigation Keys.....	35
4.3 Main Menu	36

4.4	Advanced Menu	37
4.5	Chipset Menu	48
4.6	Boot Menu	52
4.7	Save & Exit Menu	53

SECTION 1 INTRODUCTION



This section contains general information and detailed specifications of the eBOX570. Section 1 consist of the following sub-sections:

- General Descriptions
- System Specifications
- Dimensions
- I/O Outlets
- Packing List
- Model List

1.1 General Descriptions

The eBOX570 is a low power fanless embedded system that features the 13th Gen Intel® Core™ i7-1365UE, Intel® Core™ i5-1335UE or Celeron® U300E onboard. It comes with an IP40-rated heavy-duty aluminum extrusion design, offers 9-36V DC power input with power protection, and supports -40°C to +70°C extended temperature range*, thus enabling reliable operation in harsh environments.

To minimize deployment time, eBOX570 supports multiple I/O connections including 2 LAN ports, 6 USB 3.2 ports, 2 USB 2.0 ports, 2 COM ports, 2 HDMI, plus one SIM slots is provided for remarkable mobile availability. It is making perfectly suitable for Retail, Surveillance, Robotic Control, AMR Machine vision, and more.

Features

- 13th gen Intel® Core™ processor (Raptor Lake P)
- Fanless design with operating temperature from -40°C to 70°C
- 1 DDR4 SO-DIMM for up to 32GB of memory
- Supports the USB power on/off control function
- Supports high-speed NVMe storage (M.2 Key M 2280)
- Supports Intel® vPro and TPM 2.0

Reliable and Stable Design

The embedded system supports 13th gen Intel® Core™ i7-1365UE, Intel® Core™ i5-1335UE or Celeron® U300E processors (TDP 15W), along with compact size and multiple high speed USB ports design that make it the best solution for Retail, Surveillance, Robotic Control, AMR Machine vision, and more.

Flexible Connectivity

The eBOX570 comes with I/O interfaces including two RS-232/422/485 ports, six USB 3.2 ports, two USB 2.0 ports, two HDMI and two GbE.

Embedded O.S. Supported

The eBOX570 with 13th generation platform supports Windows® 11 IoT and Linux.

Storage Supported

In terms of storage, the eBOX570 supports one M.2 Key M 2280 socket for storage.

1.2 System Specifications

1.2.1 CPU

- **CPU (13th gen)**
 - Intel® Core™ i7-1365UE(1.70 GHz, 15W)
 - Intel® Core™ i5-1335UE (1.3 GHz, 15W)
 - Intel® Celeron® U300E (1.1 GHz, 15W)

- **Chipset**
 - SoC integrated

- **BIOS**
 - American Megatrends Inc. UEFI (Unified Extensible Firmware Interface) BIOS.

- **System Memory**
 - 1 x 260-pin DDR4-3200 SO-DIMM, up to 32GB

1.2.2 I/O System

- **Display**
 - 2 x HDMI 1.4b (Resolution: 4096 x 2160@30Hz)

- **Ethernet**
 - 1 x 10/100/1000 Mbps with Intel® I210-IT, supporting Wake-on-LAN and equipped with a PXE Boot ROM
 - 1 x 10/100/1000 Mbps with Intel® I219-LM, supporting Wake-on-LAN, PXE Boot ROM, and Intel® AMT

- **USB Ports**
 - 4 x USB 3.2 Gen2x1 (10G) type A
 - 2 x USB 3.2 Gen1x1 (5G) type A
 - 2 x USB 2.0

- **Serial Ports**
 - 2 x RS-232/422/485 with autoflow (COM1~COM2)
Baud rate support up to 115200

- **Expansion Interface**
 - 1 x Full-size PCI Express Mini Card slot (USB 2.0 + PCIe + SIM signal)
 - 1 x M.2 Key E 2230 socket (for Wi-Fi 6E) (USB 2.0 + PCIe signal)
 - 1 x NVMe by M.2 Key M 2280 (for storage)(SATA3/PCIe gen3 x4 signal, selectable through the BIOS)

- **Storage**
 - 1 x NVMe by M.2 Key M 2280

- **Indicator**
 - 1 x Green LED for system power
 - 1 x RED LED for HDD active

- **Switch**
 - 1 x ATX PWR switch
 - 1 x Remote PWR switch
 - 1 x Reset switch
- **Antenna & SIM**
 - 2 x SMA type openings for antenna
 - 1 x internal SIM slot
- **TPM 2.0**
 - 1 x ST33HTPH2X32AHE4

1.2.3 System Specifications

- **System Block diagram**

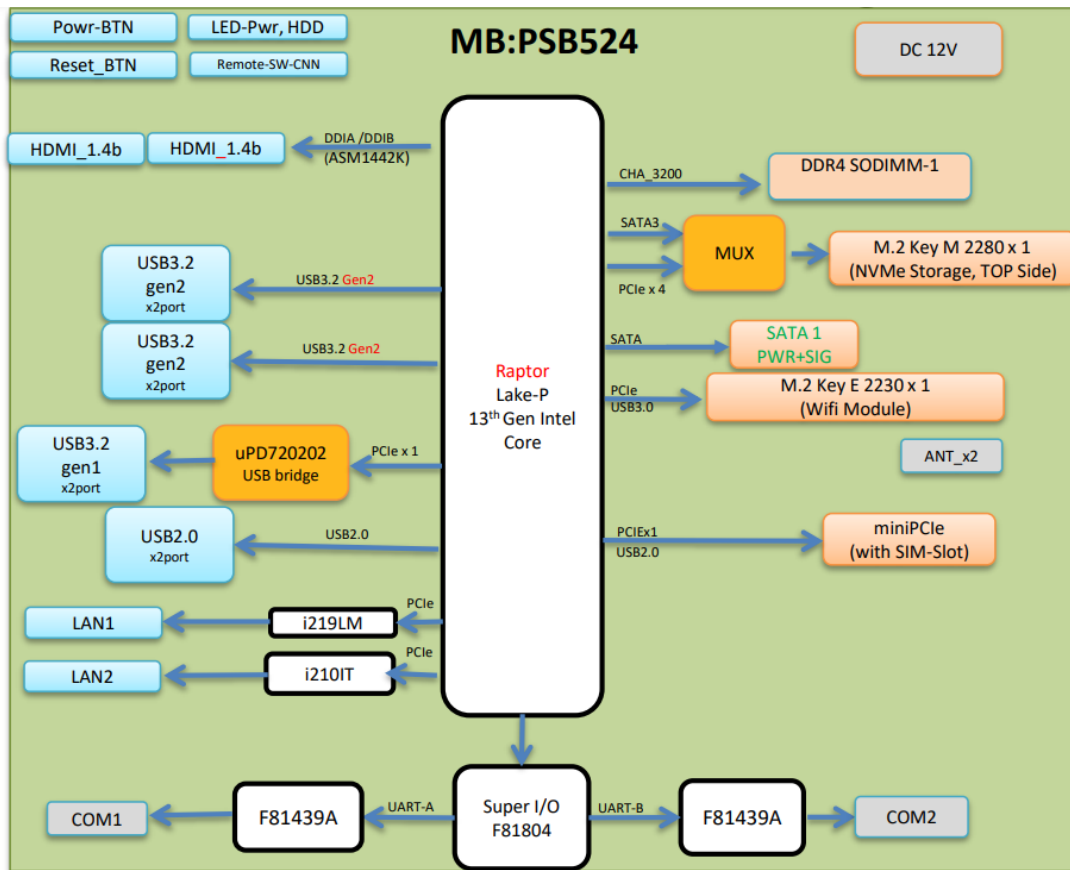

- **Watchdog Timer**
 - 1~255 seconds or minutes; up to 255 levels.
- **Power Supply**
 - 12V DC input $\pm 5\%$ (phoenix type connector)
- **Operation Temperature**
 - -40°C to $+70^{\circ}\text{C}$ (-4°F to $+149^{\circ}\text{F}$) (with W.T. DRAM & NVMe, CPU TDP 15W)

- -40°C to +65°C (-4°F to +149°F) (with STD DRAM & NVMe, CPU TDP 15W)
- **Storage Temperature**
 - -40°C ~+85°C (-40 °F ~ 185°F)
- **Humidity**
 - 10% ~ 95% (non-condensation)
- **Shock**
 - IEC 60068-2-27 (w/M.2 NVMe SSD: 50G@wall mount, half sine,11 ms duration)
- **Vibration Endurance**
 - IEC 60068-2-64 (w/M.2 NVMe SSD: 3Grms STD, random, 5 - 500 Hz,1 hr/axis)
- **Weight**
 - 2 kg (4.4 lb) without package
 - 2.5 kg (5.5 lb) with package
- **Dimension**
 - 120 mm (4.72") x 178 mm (7.01") x 65 mm (2.56")

1.2.4 Driver CD Contents

Please download the following eBOX570 drivers from the Axiomtek official website.

- Ethernet
- Chipset
- Graphic
- Serial Port
- Intel® ME



【Note】 : All specifications and images are subject to change without notice.

1.3 Dimensions

The following diagrams show dimensions and outlines of the eBOX570.

1.3.1 System Dimensions

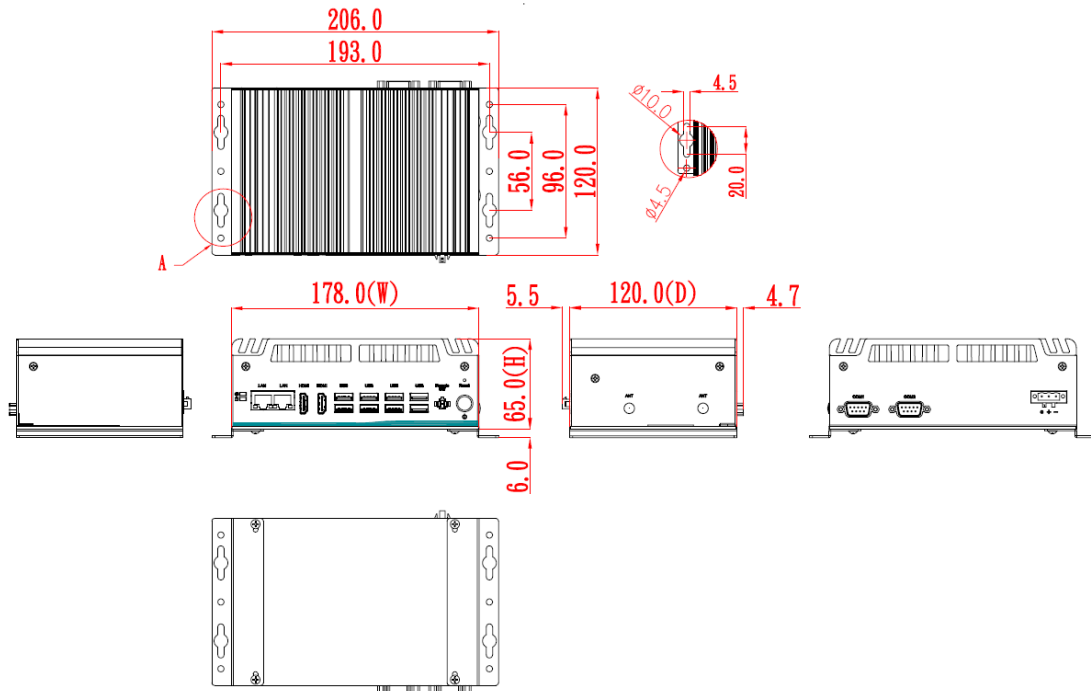

1.3.2 Wall-mount Bracket Dimensions

Users can get 4pcs truss head M3*6L screws for fixing the wall mount kit from the accessories box.

Note: When users install wall mount kit, please turn the LAN ports side outlet towards the floor.

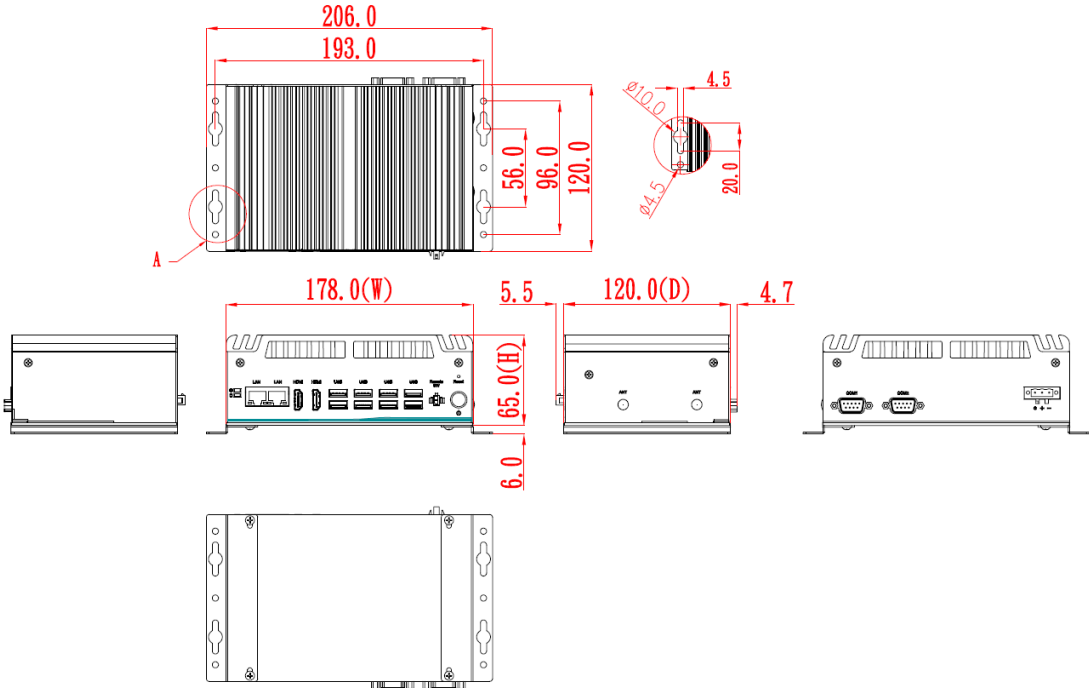

Wall-mount Bracket Assembly Drawing

Users can get 4pcs truss head M3*6L screws for fixing the wall mount kit from the accessories box.

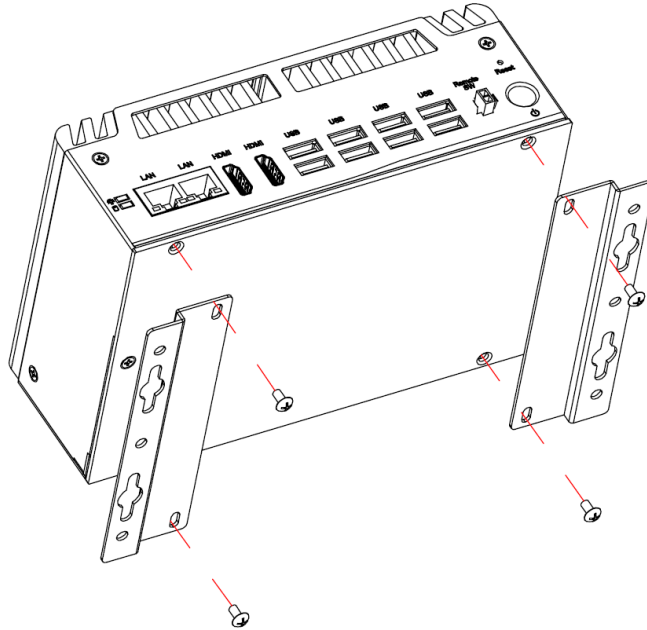

Note : If users install the screws in drywall, use the hollow wall anchors to ensure that unit does not pull away from the wall due to prolonged strain between the cable and power connector.

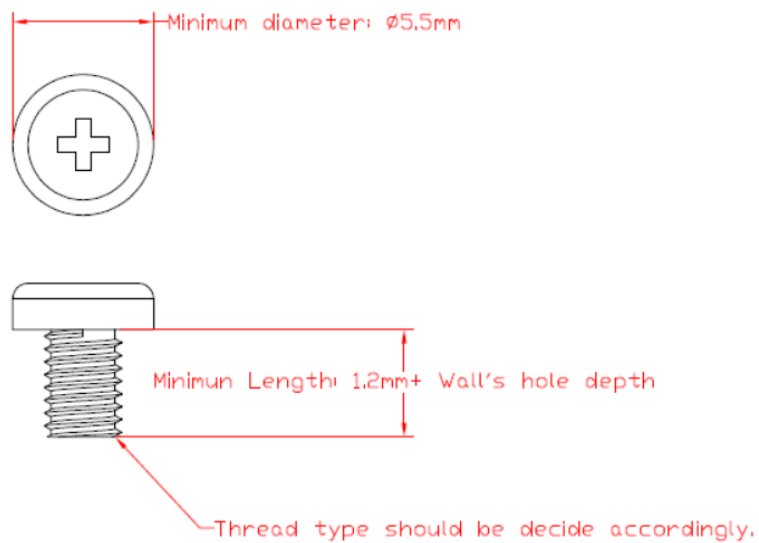

1.3.3 Din-Rail Bracket Dimensions

Users can get 8pcs truss head M3*6L screws for fixing the wall mount kit from the accessory box.

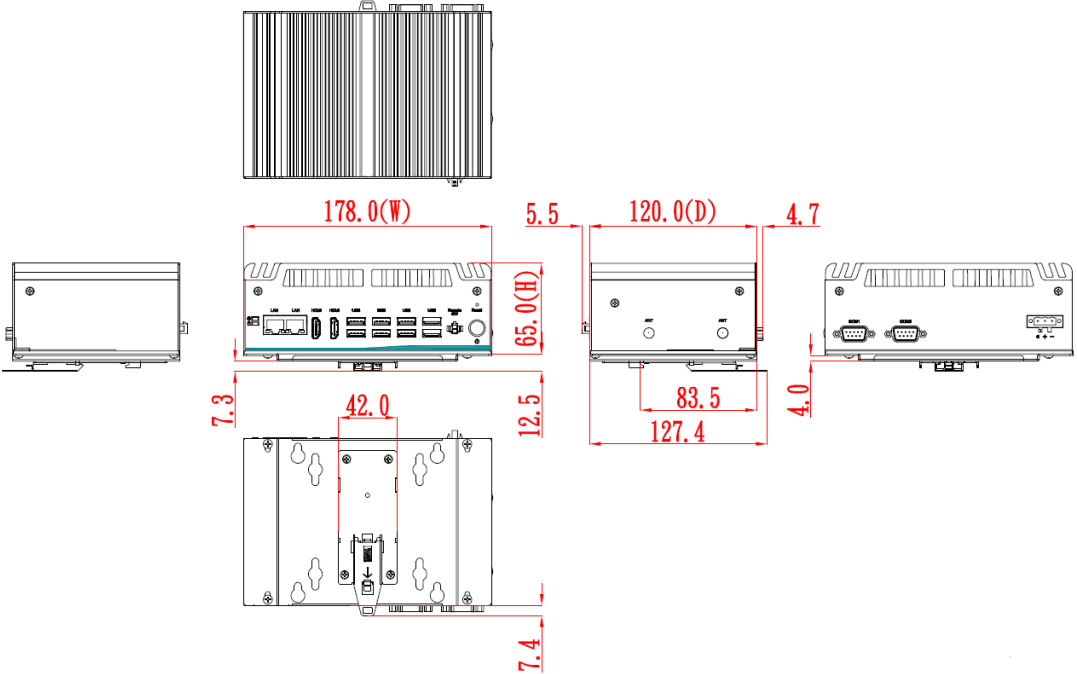

Din-Rail Bracket Assembly Drawing

Users can get 8pcs truss head M3*6L screws for fixing the Din Rail kit from the accessory box.

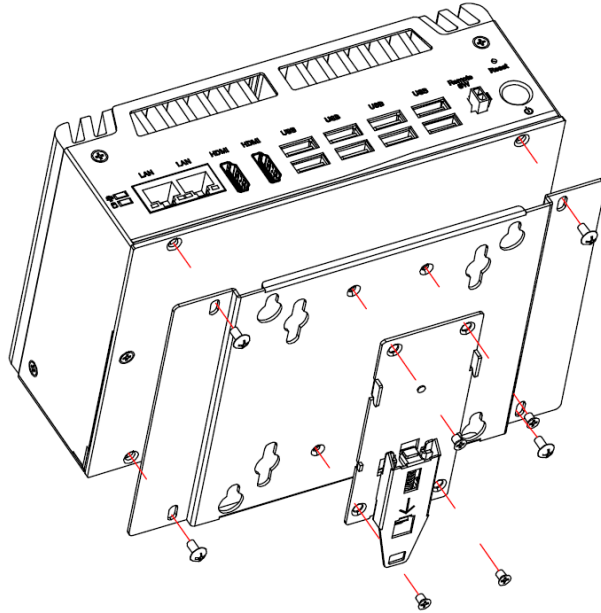

1.3.4 VESA Mount Bracket Dimensions

Users can get 4pcs truss head M3*6L screws for fixing the VESA mount kit from the accessory box.

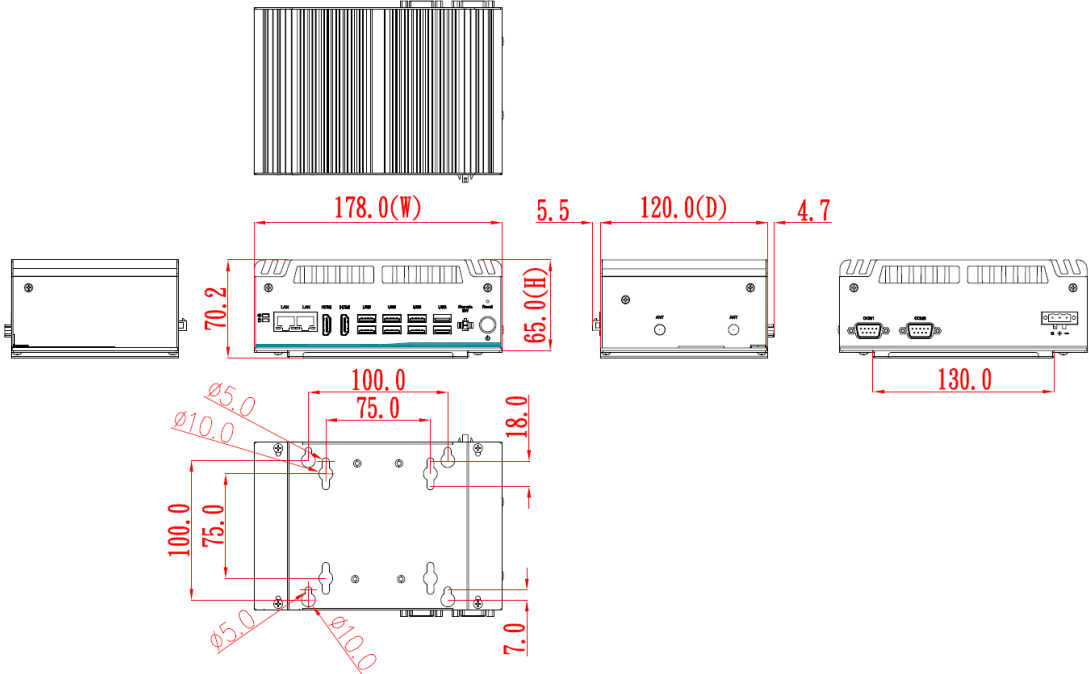

VESA Mount Bracket Assembly Drawing

Users can get 4pcs truss head M3*6L screws for fixing the Din Rail kit from the accessory box.

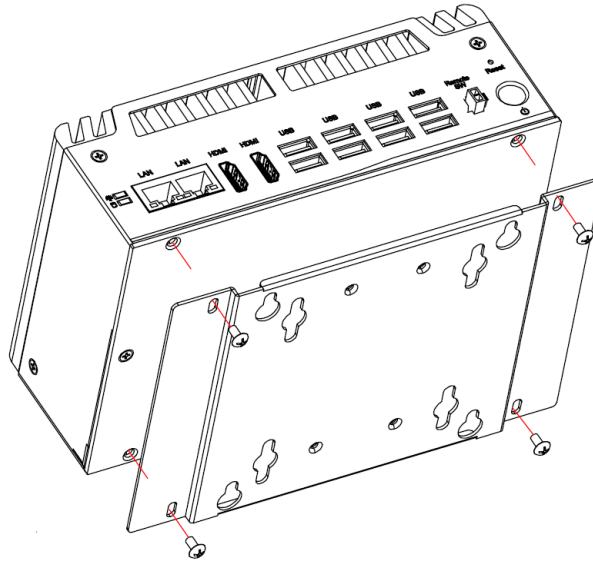

1.4 I/O Outlets

The following figures show I/O outlets on the eBOX570.

Front View

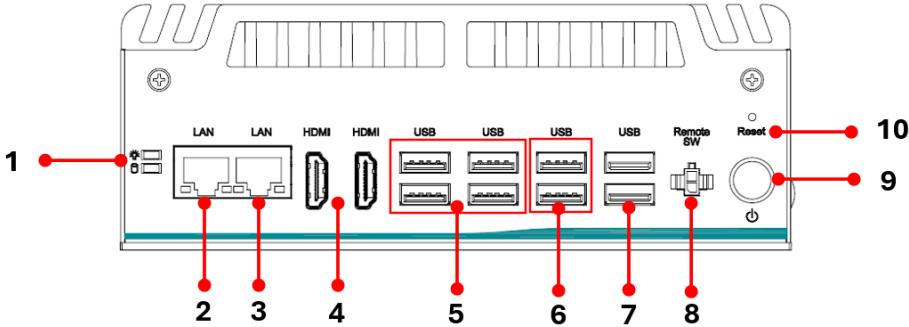

Rear View

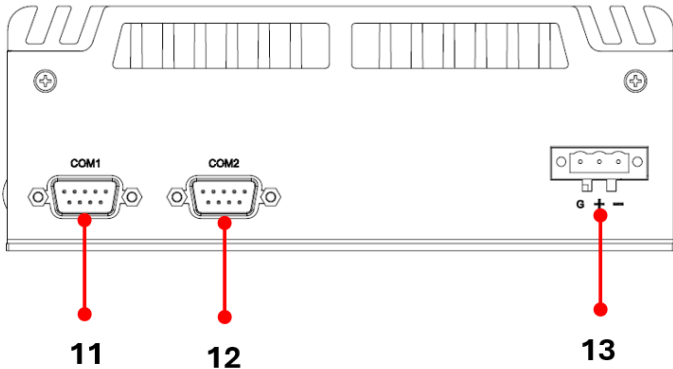

Side View

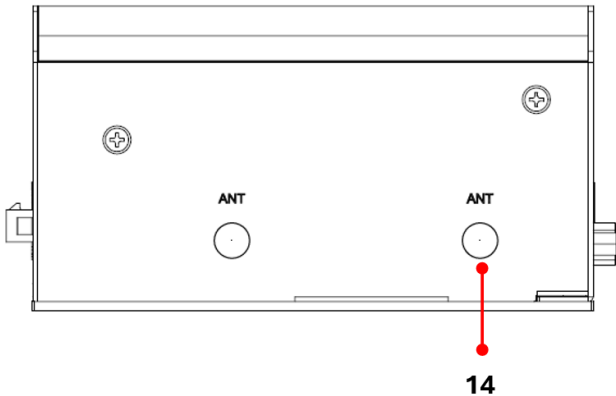

1	LEDs	8	1 x Remote power switch
2	1 x I210-IT	9	1 x Power button
3	1 x I219-LM	10	1 x Reset switch
4	2 x HDMI	11	1 x RS-232/422/485 (COM1)
5	4 x USB 3.2 Gen2	12	1 x RS-232/422/485 (COM2)
6	2 x USB 3.2 Gen1	13	1 x Phoenix type connector
7	2 x USB 2.0	14	2 x Opening Antenna

1.5 Packing List

The eBOX570 comes with the following bundle package:

- eBOX570 System Unit x 1
- Remote power switch cable x 1
- Foot pad x 4
- Screw pack x 1

1.6 Model List

eBOX570-13P-i7	Fanless embedded system with Intel® Core™ i7-1365UE, 2 HDMI, 2 LANs, 8 USB, 2 COM, and 12 VDC
eBOX570-13P-i5	Fanless embedded system with Intel® Core™ i5-1335UE, 2 HDMI, 2 LANs, 8 USB, 2 COM, and 12 VDC
eBOX570-13P-Cel	Fanless embedded system with Intel® Celeron® U300E, 2 HDMI, 2 LANs, 8 USB, 2 COM, and 12 VDC

Please contact Axiomtek's distributors immediately in case any abovementioned items are missing.

SECTION 2 HARDWARE INSTALLATION

The eBOX570 is convenient for various hardware configurations, such as DRAM, NVMe, PCI Express Mini card modules. Section 2 contains guidelines for hardware installation.

2.1 Installation of DRAM Module

Step 1 Turn off the system and unplug the power cord.

Step 2 Loosen five screws to remove bottom cover and locate DRAM slot within the red line as marked.

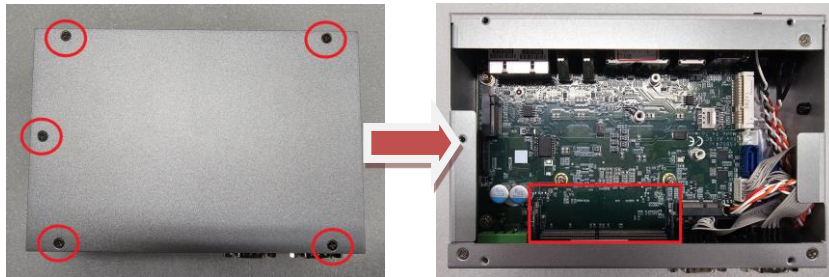

Step 3 Hold the edge of the DRAM and insert it into the DRAM notch at an angle of approximately 30 degrees, and then gently press it down until the latches are buckled.

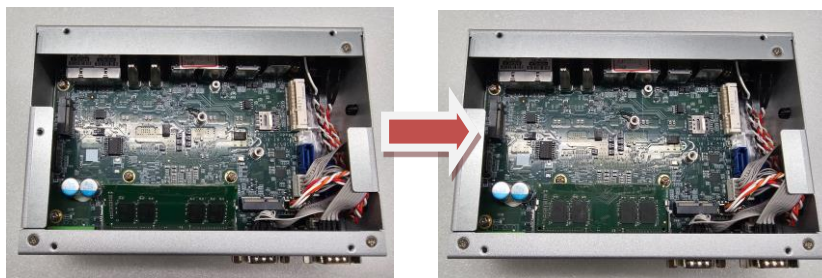

Step 4 Put the bottom cover and fasten all the screws onto the system.

2.2 Installation of Mini PCIe Module (CN11)

The eBOX570 provides one full-size mini-PCIe socket with SIM card support. Customers can use this socket for install wireless modules.

Install WiFi Mini PCIe Module, please follow the instructions as blow:

- Step 1** Turn off the system and unplug the power cord.
- Step 2** Loosen five screws to remove bottom cover and locate Mini card slot within the red line as marked.

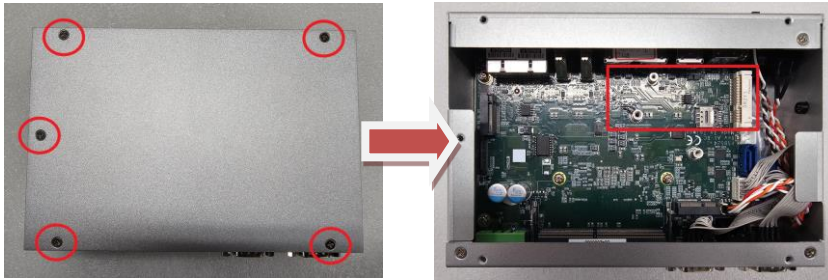

- Step 3** Insert the module on a 45-degree angle into the mPCIe slot and secure the module with M3x2 screw.



- Step 4** Remove the antenna cover from system, fix the SMA connector of the IPEX-to-SMA cable to one of the antenna apertures on the side of panel.

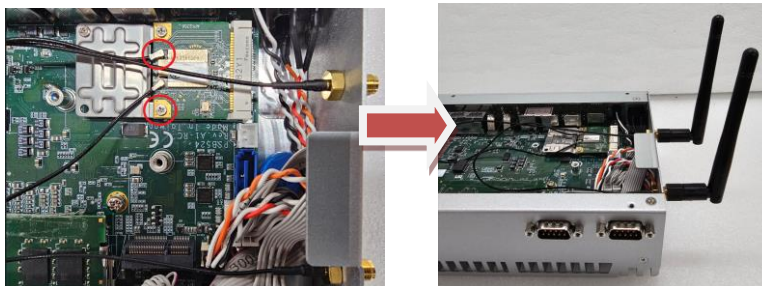

- Step 5** Put the bottom cover and fasten all screws back onto the system.

Install LTE Mini PCIe Module, please follow the instructions as blow:

Step 1 Turn off the system and unplug the power cord.

Step 2 Loosen five screws to remove bottom cover and locate PCIe mini card slot within the red line as marked.

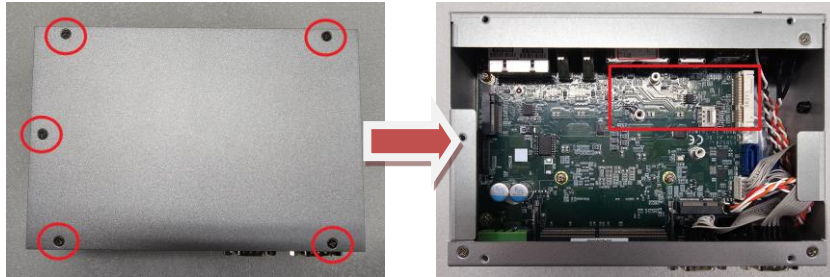

Step 3 Insert the corresponding SIM card into SIM socket (CN9) before you install the mini-PCIe module.

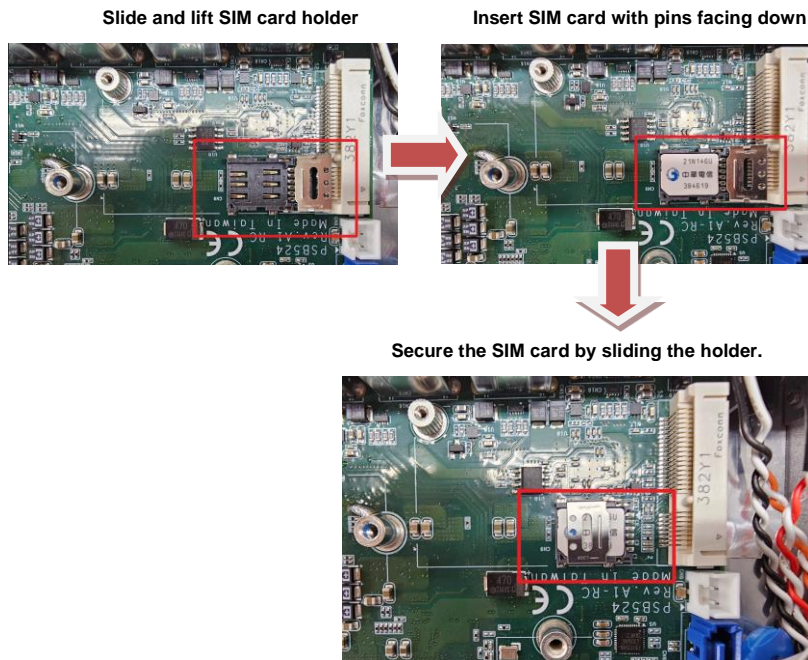

Step 4 Insert the LTE mPCIe module on a 45-degree angle into the mPCIe slot and secure the module with M3x2 screw.



Step 5 Remove the antenna cover from system, fix the SMA connector of the IPEX-to-SMA cable to one of the two antenna apertures on the side panel.

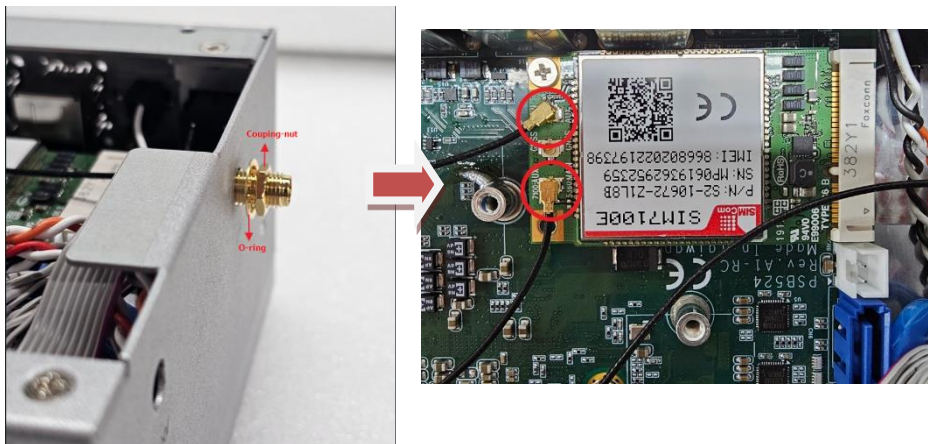

【Note】 : Please use an extended bracket when using a half-size Mini card



【Note】 : If users install Wi-Fi module, the installation procedure is the same as with LTE module, but there is no need to insert a sim card.

2.3 Installation of M.2 Key E Mini PCIe Module (CN3)

The eBOX570 equipped with an M.2 Key E 2230 socket for users to install an Wi-Fi 6E wireless module.

Step 1 Turn off the system and unplug the power cord.

Step 2 Loosen five screws to remove bottom cover and locate M.2 key E mini card slot within the red line as marked.

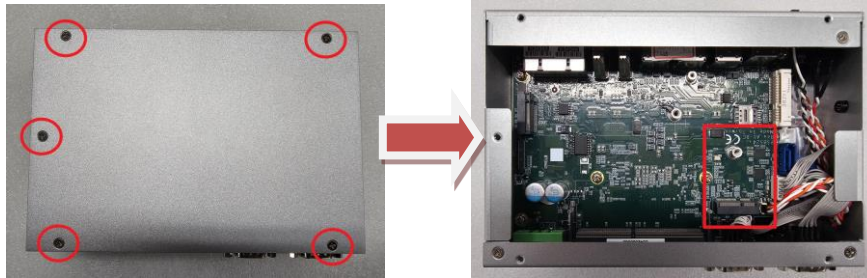

Step 3 Insert Wi-Fi wireless module into the slot and tighten the card securely to the mainboard with M3x3 screw.

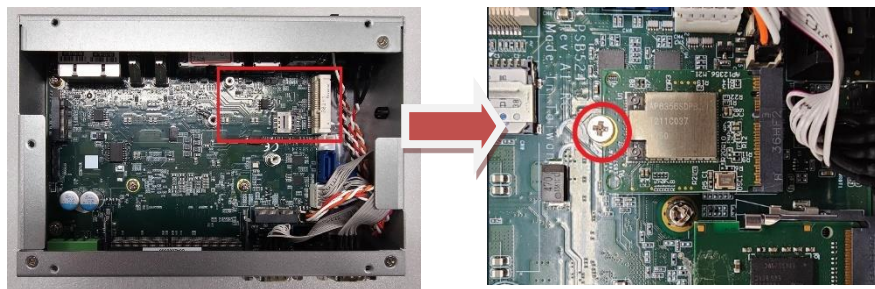

Step 4 Attach the corresponding IPEX-to-SMA cable (2pcs) to the module as below red marked.

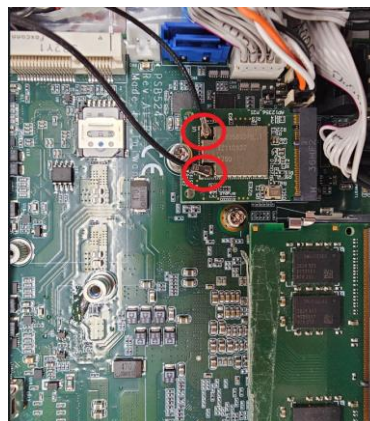

Step 5 Remove the antenna cover from system, fix the SMA connector of the IPEX-to-SMA cable to one of the two antenna apertures on the side of panel.

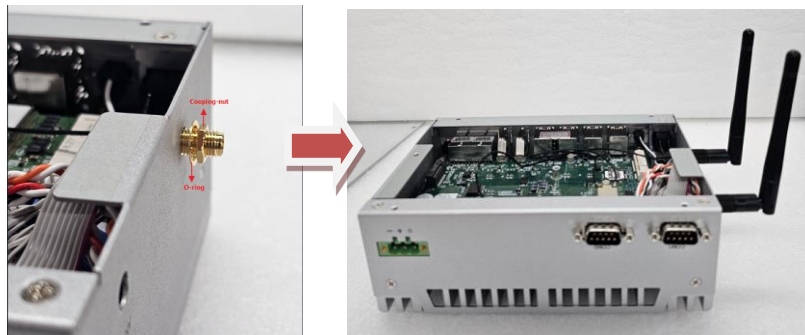

Step 6 Put the bottom cover and fasten all screws back onto the system.

2.4 Installation of NVMe SSD Module (CN10)

The eBOX570 equipped with an M.2 Key M 2280 socket (PCIex4 signal) for users to install an NVMe SSD module. Please refer to the following instructions and illustrations for the installation of the NVMe SSD module.

Step 1 Turn off the system and unplug the power cord.

Step 2 Loosen five screws to remove bottom cover and locate M.2 key E mini card slot within the red line as marked.

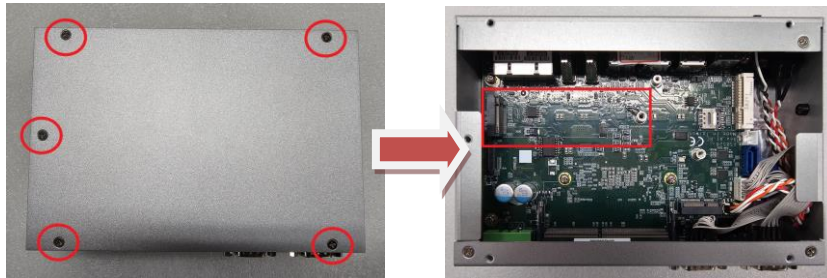

Step 3 Insert M.2 NVMe module into the slot and tighten the screw.

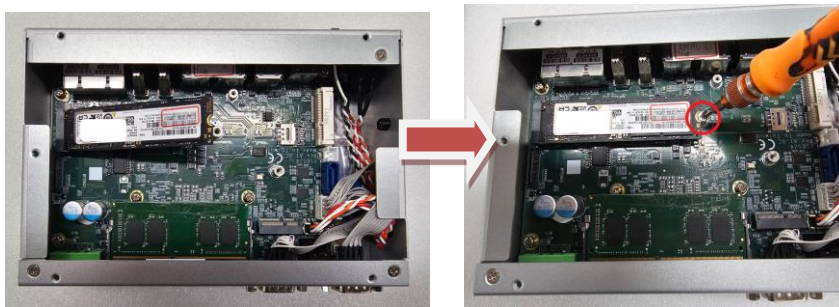

Step 4 Put the top cover and fasten all screws back onto the system.

This page is intentionally left blank.

SECTION 3 JUMPER & CONNECTOR SETTINGS

Proper jumper settings configure the eBOX570 to meet various application needs.-Hereby all jumpers settings along with their default settings are listed for devices onboard.

3.1 Locations of Jumpers & Connectors

PSB524 Top View

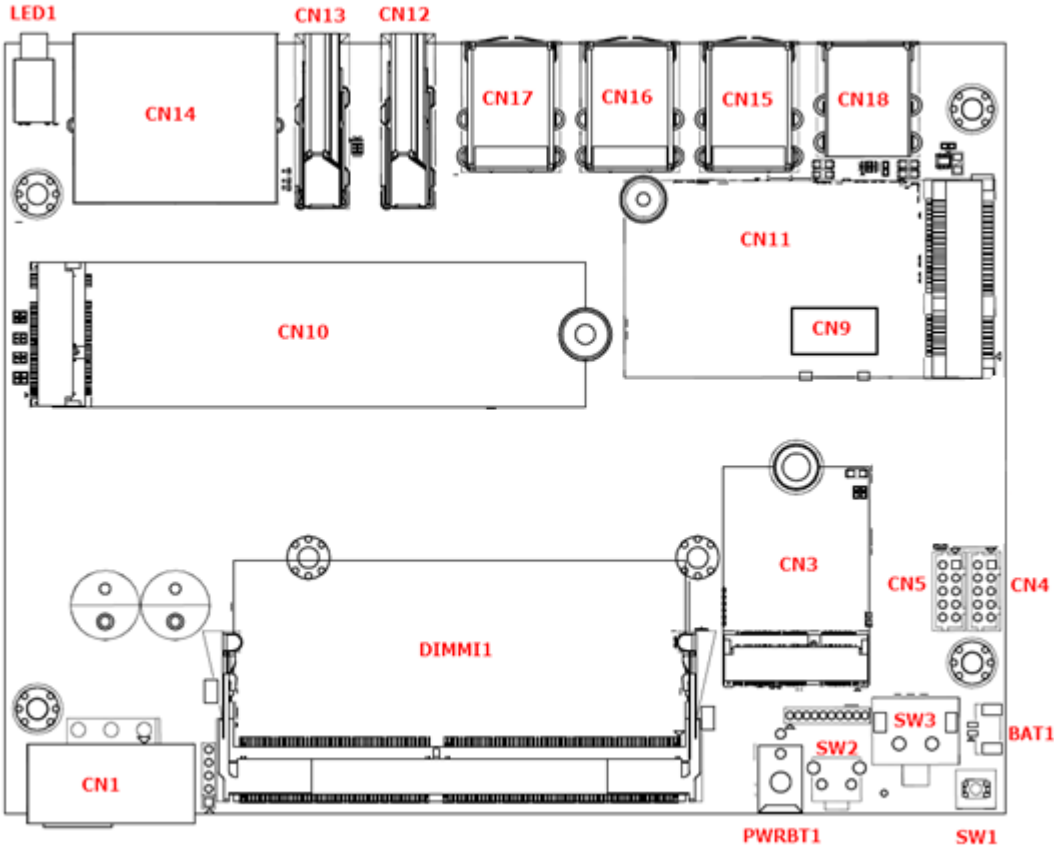

PSB524 Bottom View

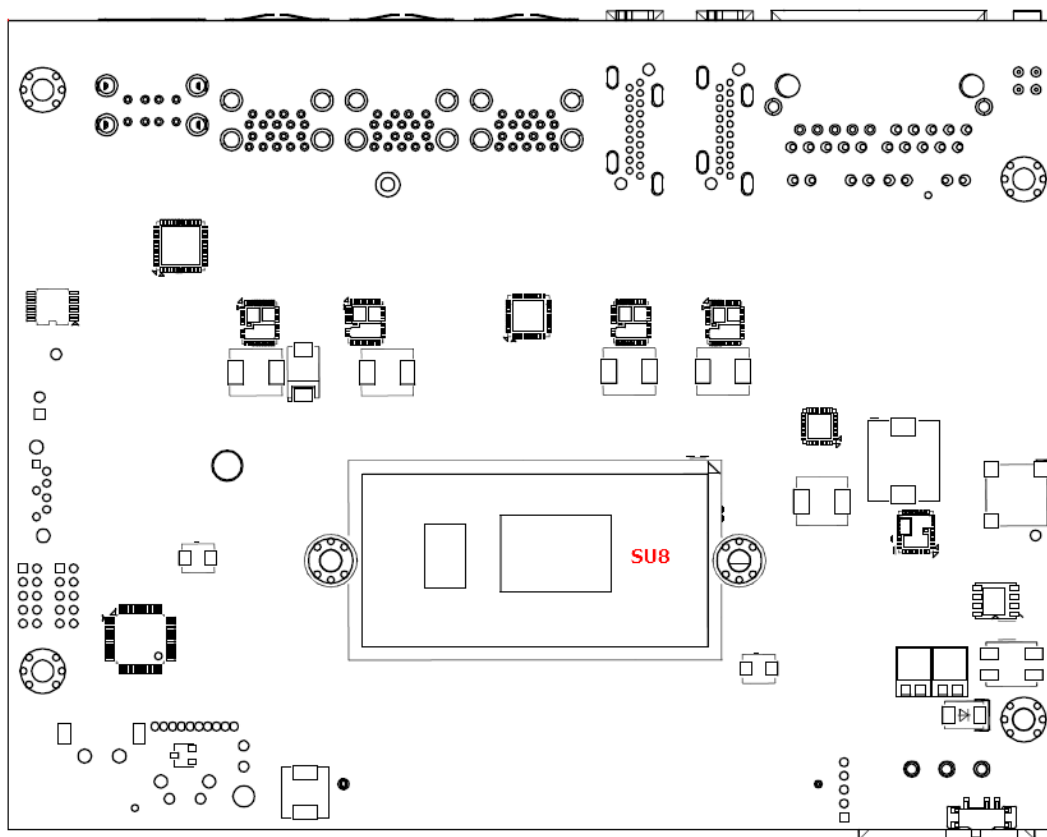

【Note】 : *It is strongly recommended that any unmentioned jumper settings should not be modified without instructions by Axiomtek FAEs. Any modifications without instructions might cause system failure.*

3.2 Clear CMOS Setting

please see the following setting for clear CMOS.

3.2.1 Clear CMOS (SW1)

Use the switch SW1 to for clear CMOS.

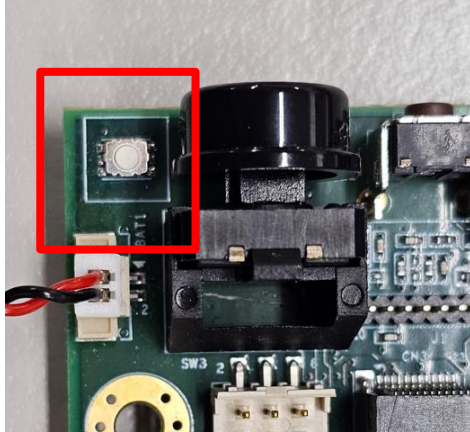

3.3 Connectors

Please refer to below connector table to get their pin assignments.

External Connectors	Sections
DC-in Phoenix Power Connector (CN1)	3.3.1
HDMI Connector (CN12, CN13)	3.3.2
Serial Port Connector (CN4, CN5)	3.3.3
USB 3.2 Connector (CN15, CN16, CN17)	3.3.4
USB 2.0 Connector (CN18)	
Ethernet Connector (LAN 1~ LAN 2)	3.3.5
ATX Power On/Off Button (via flat cable)	3.3.6
Reset Button (via flat cable)	3.3.7
Remote Power Switch (via flat cable)	3.3.8
SIM Slot (CN9)	3.3.9
Internal Connectors	Sections
Full-Size Express Mini Card slot (CN22)	3.3.10
M.2 Key E (CN3)	3.3.11
M.2 Key M (CN10)	3.3.12

3.3.1 DC-in Phoenix Power Connector (CN1)

The system supports 9~36V Phoenix DC-in connector for system power input.

Pins	Signals
1	GND
2	V+
3	V-

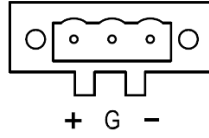

3.3.2 HDMI Connector (CN12, CN13)

The HDMI (High-Definition Multimedia Interface) is a compact digital interface which is capable of transmitting high-definition video and high-resolution audio over a single cable.

Pins	Signals	Pins	Signals
1	HDMI OUT_DATA2+	11	GND
2	GND	12	HDMI OUT Clock-
3	HDMI OUT_DATA2-	13	N.C.
4	HDMI OUT_DATA1+	14	N.C.
5	GND	15	HDMI OUT_SCL
6	HDMI OUT_DATA1-	16	HDMI OUT_SDA
7	HDMI OUT_DATA0+	17	GND
8	GND	18	+5V
9	HDMI OUT_DATA0-	19	HDMI_HTPLG
10	HDMI OUT Clock+		

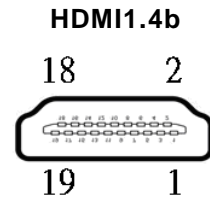

3.3.3 Serial Port Connector (CN4,CN5)

The system has two serial ports. COM1~COM2 are RS-232/422/485 ports. Please refer to Chapter 4 for the detail of BIOS setting.

Baud rate support up to 115200

Pins	RS-232	RS-422	RS-485
1	DCD, Data Carrier Detect	TX-	Data-
2	RXD, Receive Data	TX+	Data+
3	TXD, Transmit Data	RX+	No use
4	DTR, Data Terminal Ready	RX-	No use
5	GND, Ground	No use	No use
6	DSR, Data Set Ready	No use	No use
7	RTS, Request To Send	No use	No use
8	CTS, Clear To Send	No use	No use
9	RI, Ring Indicator	No use	No use

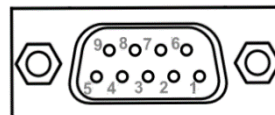

3.3.4 USB 3.2 Connector (CN15, CN16, CN17) / USB 2.0 Connector (CN18)

The system has four USB 3.2 gen2 (10GB/s), two USB 3.2 gen1 (5GB/s), two USB 2.0 ports which are ideal for connecting USB devices, such as scanner, camera, and USB devices, etc.

USB 3.2 Connector (CN15-CN17)

Pins	Signal USB Port 0	Pins	Signal USB Port 1
1	USB_VCC (+5V level standby power)	10	USB_VCC (+5V level standby power)
2	USB_Data-	11	USB_Data-
3	USB_Data+	12	USB_Data+
4	GND	13	GND
5	SSRX-	14	SSRX-
6	SSRX+	15	SSRX+
7	GND	16	GND
8	SSTX-	17	SSTX-
9	SSTX+	18	SSTX+

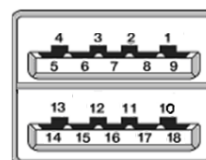

USB 2.0 Connector (CN18)

Pins	Signal USB Port 0	Pins	Signal USB Port 1
1	USB_VCC (+5V level standby power)	5	USB_VCC (+5V level standby power)
2	USB_Data-	6	USB_Data-
3	USB_Data+	7	USB_Data+
4	GND	8	GND

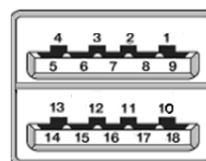

3.3.5 Ethernet Connector (LAN1~LAN2)

The board has two RJ-45 Gbe ports connectors, one LAN port is designed by Intel i219-LM and three LAN ports are Intel i210-IT.

Pins	LAN Signal	Pins	LAN Signal
L1	MDI0+	L5	MDI2+
L2	MDI0-	L6	MDI2-
L3	MDI1+	L7	MDI3+
L4	MDI1-	L8	MDI3-
A	Activity link LED(Yellow) OFF: No link Blinking: Link established; data activity detected		
B	Speed LED OFF: 10Mbps data rate Green: 100Mbps data rate Orange: 1Gbps data rate		

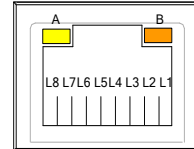

3.3.6 ATX Power button

The ATX power button is on the I/O side. It can allow users to control eBOX570 power on/off.

Functions	Descriptions
On	Turn on/off system
Off	Keep system status



3.3.7 Reset Switch

The Reset button can allow users to reset eBOX570 system.

Functions	Descriptions
On	Reset system
Off	Keep system status



3.3.8 Remote Power Switch

One 2-pin connector output for remote power on/off switch.

Functions	Descriptions
Short(1-2)	Turn on/off system
Open	Keep system status

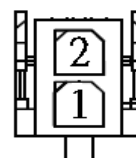

3.3.9 SIM Card Slots (CN9)

The eBOX570 includes one SIM slot: CN9 on top side that support mini PCIe slot (for CN11), It is mainly used in wireless network application on CN11.

Pins	Signals
1	PWR
2	RST
3	CLK
4	NC
5	GND
6	VPP
7	I/O
8	NC

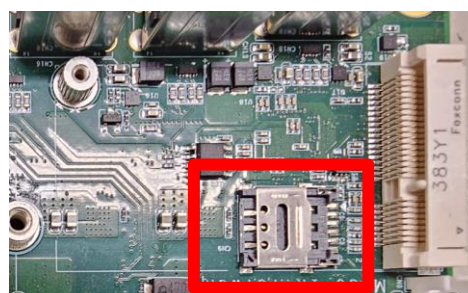

3.3.10 Full-Size PCI Express Mini Card Slot (CN11)

The eBOX570 supports one full-size PCI-Express Mini Card slot.

CN11 is applying for PCI-Express and USB signals; PCI-Express complies with PCI-Express Mini Card Spec. V1.2. Thus, users can install WLAN/WWAN cards into this slot.

※ CN11 supports SIM slot.

Pins	Signals	Pins	Signals
1	WAKE#	2	+3.3VSB
3	No use	4	GND
5	No use	6	+1.5V
7	CLKREQ#	8	No use
9	GND	10	No use
11	REFCLK-	12	No use
13	REFCLK+	14	No use
15	GND	16	No use

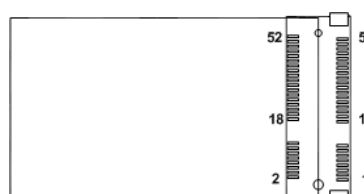

17	No use	18	GND
19	No use	20	W_DISABLE#
21	GND	22	PERST#
23	PE_RXN3/	24	+3.3VSB
25	PE_RXP3/	26	GND
27	GND	28	+1.5V
29	GND	30	SMB_CLK
31	PE_TXN3/	32	SMB_DATA
33	PE_TXP3/	34	GND
35	GND	36	USB_D8-
37	GND	38	USB_D8+
39	+3.3VSB	40	GND
41	+3.3VSB	42	No use
43	GND	44	No use
45	No use	46	No use
47	No use	48	+1.5V
49	No use	50	GND
51	No use	52	+3.3VSB



3.3.11 M.2 2230 Key E slot (CN3)

The system comes with one M.2 Key E socket (PCIe & USB2.0)

Pins	Signals	Pins	Signals
1	GND	2	+3.3V_SBY
3	USB_D+	4	+3.3V_SBY
5	USB_D-	6	NC
7	GND	8	M.2_BT_PCMCLK
9	CNVI_WGR_DATA1_D-	10	M.2_BT_PCMRST
11	CNVI_WGR_DATA1_D+	12	M.2_BT_PCMIN
13	GND	14	M.2_BT_PCMOUT
15	CNVI_WGR_DATA0_D-	16	NC
17	CNVI_WGR_DATA0_D+	18	GND
19	GND	20	UART_BT_WAKE-
21	CNVI_WGR_CLK_D-	22	CNVI_BRI_RSP
23	CNVI_WGR_CLK_D+	24	Key E
25	Key E	26	
27		28	
29		30	

31		32	CNVI_RGI_DT
33	GND	34	CNVI_RGI_RSP
35	PCIE_TX_+	36	CNVI_BRI_DT
37	PCIE_TX_-	38	CL_RST
39	GND	40	CL_DATA
41	PCIE_RX_+	42	CL_CLK
43	PCIE_RX_-	44	CNVI_GNSS_PA_BLANKING
45	GND	46	CNVI_MFUART_TXD
47	CLK_PCIE_+	48	CNVI_MFUART_RXD
49	CLK_PCIE_-	50	SUSCLK (+3.3V Level)
51	GND	52	PERST# (+3.3V Level)
53	CLKREQ0#	54	BT_RF_KILL
55	PEWAKE0#	56	WIFI_RF_KILL
57	GND	58	NC
59	CNVI_WT_DATA1_D-	60	NC
61	CNVI_WT_DATA1_D+	62	NC
63	GND	64	GND
65	CNVI_WT_DATA0_D-	66	NC
67	CNVI_WT_DATA0_D+	68	NC
69	GND	70	NC
71	CNVI_WT_CLK_D-	72	+3.3V_SBY
73	CNVI_WT_CLK_D+	74	+3.3V_SBY
75	GND		

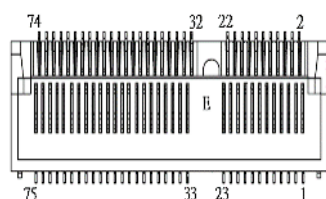

3.3.12 M.2 2280 Key M slot (CN10)

The M.2 2280 Key M for NVMe/SATA Module by BIOS select (default SATA).

Pins	Signals	Pins	Signals
1	GND	2	+3.3V
3	GND	4	+3.3V
5	PCIEx4_B_RX_DN3	6	NC
7	PCIEx4_B_RX_DP3	8	NC
9	GND	10	KEY_M_LED_N
11	PCIEx4_B_TX_DN3	12	+3.3V
13	PCIEx4_B_TX_DP3	14	+3.3V
15	GND	16	+3.3V
17	PCIEx4_B_RX_DN2	18	+3.3V
19	PCIEx4_B_RX_DP2	20	NC
21	GND	22	NC
23	PCIEx4_B_TX_DN2	24	NC
25	PCIEx4_B_TX_DP2	26	NC
27	GND	28	NC
29	PCIEx4_B_RX_DN1	30	NC
31	PCIEx4_B_RX_DP1	32	NC
33	GND	34	NC
35	PCIEx4_B_TX_DN1	36	NC
37	PCIEx4_B_TX_DP1	38	M.2_DEVSLP
39	GND	40	NC
41	PCIEx_mSATA_Card_RXN	42	NC
43	PCIEx_mSATA_Card_RXP	44	NC
45	GND	46	NC
47	PCIEx_mSATA_Card_TXN	48	NC
49	PCIEx_mSATA_Card_TXP	50	M2M_PLTRST_N
51	GND	52	CLKREQ5_N
53	CLKOUT5_DN	54	PCH_WAKE_N
55	CLKOUT5_DP	56	NC
57	GND	58	NC
Key M			
67	NC	68	PCH_SUSCLK
69	No use	70	+3.3V
71	GND	72	+3.3V
73	GND	74	+3.3V
75	GND		

SECTION 4 BIOS SETUP UTILITY

This section provides users with detailed descriptions in terms of how to set up basic system configurations through the BIOS setup utility.

4.1 Starting

To enter the setup screens, follow the steps below:

1. Turn on the computer and press the key immediately.
2. After press the key, the main BIOS setup menu displays. Users can access to other setup screens, such as the Advanced and Chipset menus, from the main BIOS setup menu.

It is strongly recommended that users should avoid changing the chipset's defaults. Both AMI and system manufacturer have carefully set up these defaults that provide the best performance and reliability.

4.2 Navigation Keys

The BIOS setup/utility uses a key-based navigation system called hot keys. Most of the BIOS setup utility hot keys can be used at any time during the setup navigation process. These keys include <F1>, <F2>, <Enter>, <ESC>, <Arrow> keys, and so on.



【Note】 : Some of the navigation keys differ from one screen to another.

Hot Keys	Descriptions
→← Left/Right	The Left and Right <Arrow> keys allow users to select a setup screen.
↑↓ Up/Down	The Up and Down <Arrow> keys allow users to select a setup screen or sub-screen.
+– Plus/Minus	The Plus and Minus <Arrow> keys allow users to change the field value of a particular setup item.
Tab	The <Tab> key allows users to select setup fields.
F1	The <F1> key allows users to display the General Help screen.
F2	The <F2> key allows users to Load Previous Values.
F3	The <F3> key allows users to Load Optimized Defaults.
F4	The <F4> key allows users to save any changes they made and exit the Setup. Press the <F4> key to save any changes.
Esc	The <Esc> key allows users to discard any changes they made and exit the Setup. Press the <Esc> key to exit the setup without saving any changes.
Enter	The <Enter> key allows users to display or change the setup option listed for a particular setup item. The <Enter> key can also allow users to display the setup sub- screens.

4.3 Main Menu

The Main Menu screen is the first screen users see when entering the setup utility. Users can always return to the Main setup screen by selecting the Main tab. System Time/Date can be set up as described below. The Main BIOS setup screen is also shown below.

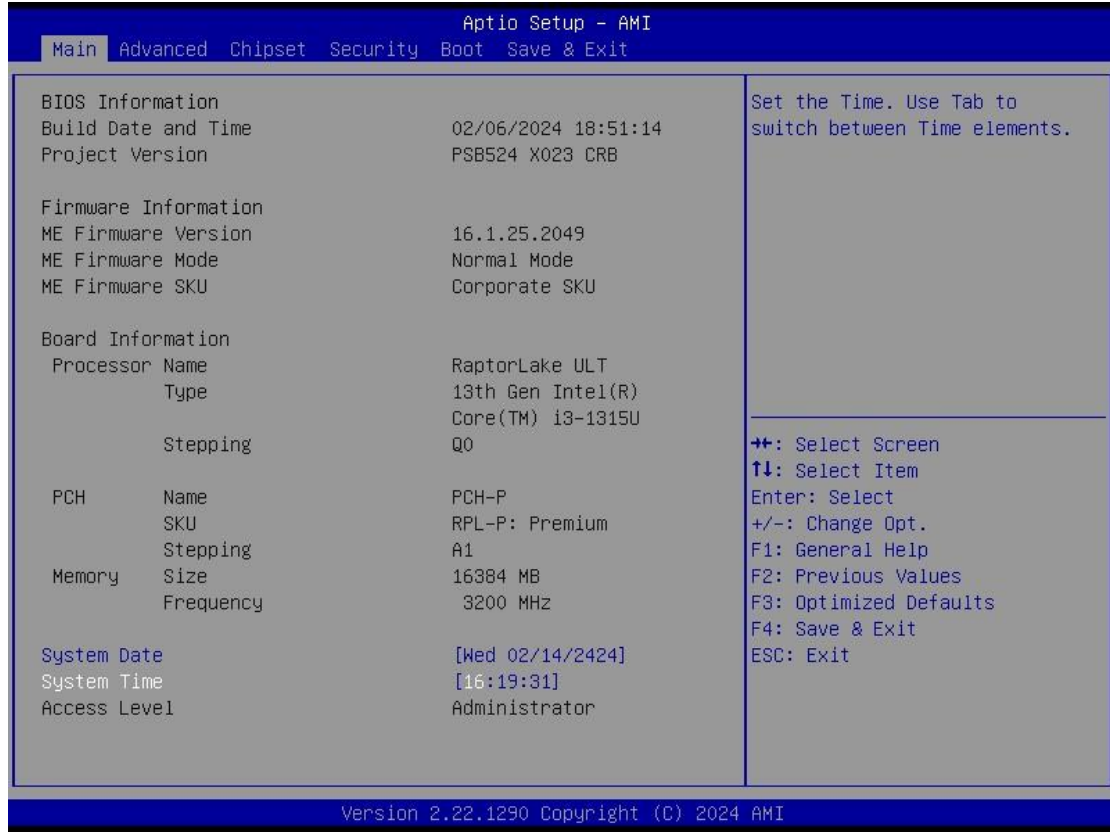

BIOS Information

Display the auto-detected BIOS information.

System Language

Choose the system default language.

System Date/Time

Use this option to change the system time and date. Highlight System Time or System Date using the <Arrow> keys. Enter new values through the keyboard. Press the <Tab> key or the <Arrow> keys to move between fields. The date must be entered in MM/DD/YY format. The time is entered in HH:MM:SS format.

Access Level

Display the access level of current user.

4.4 Advanced Menu

The Advanced menu also allows users to set configuration of the CPU and other system devices. Users can select any items in the left frame of the screen to go to sub menus:

- ▶ ACPI Settings
- ▶ Trust Computing
- ▶ CPU Configuration
- ▶ Storage Configuration
- ▶ NVMe Configuration
- ▶ AMT Configuration
- ▶ F81804 Super IO Configuration
- ▶ Hardware Monitor
- ▶ USB Configuration

For items marked with “▶”, please press <Enter> for more options.

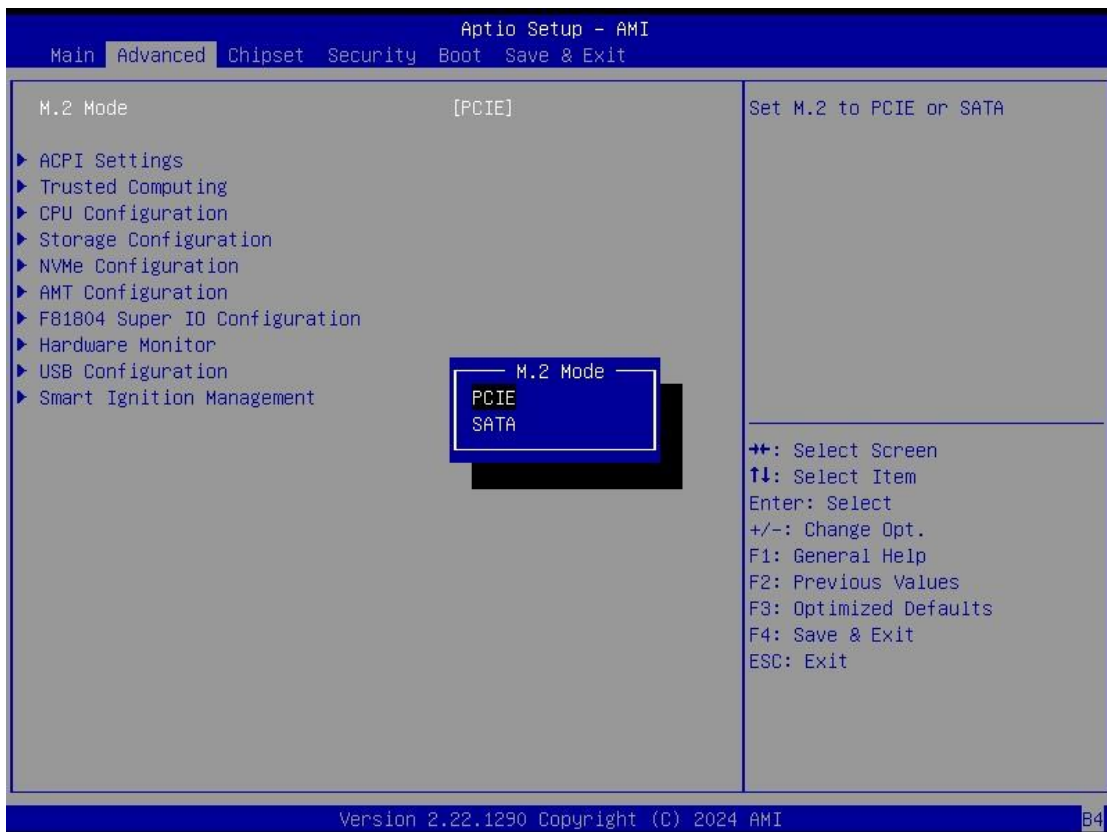

M.2 Mode

Users can select M.2 key M interface when using M.2 device via this item, default is "PCIe".

ACPI Settings

Use this screen to select options for the ACPI configuration and change the value of the selected option. A description of the selected item appears on the right side of the screen.

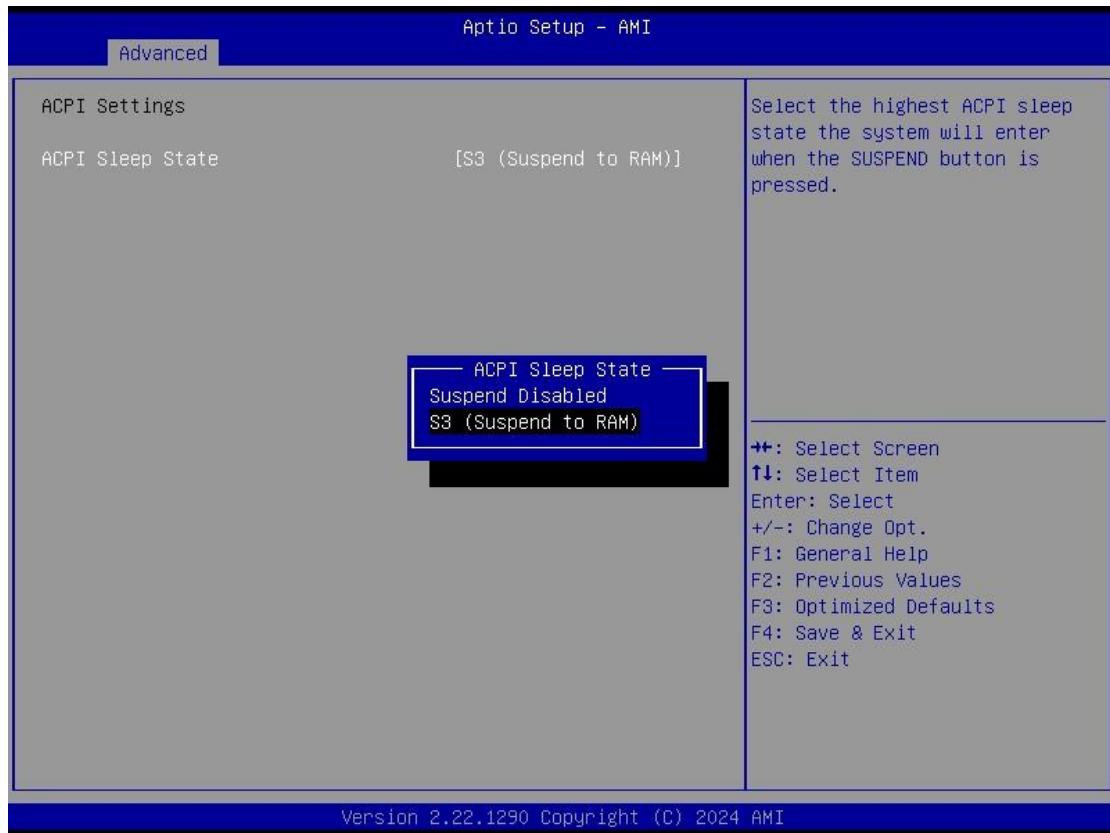

ACPI Sleep State

When the sleep button is pressed, the system will be in the ACPI sleep state.

The default is S3 (Suspend to RAM).

Trust Computing

If users install a security device, such as TPM, users will see the following information for the TPM device and status.

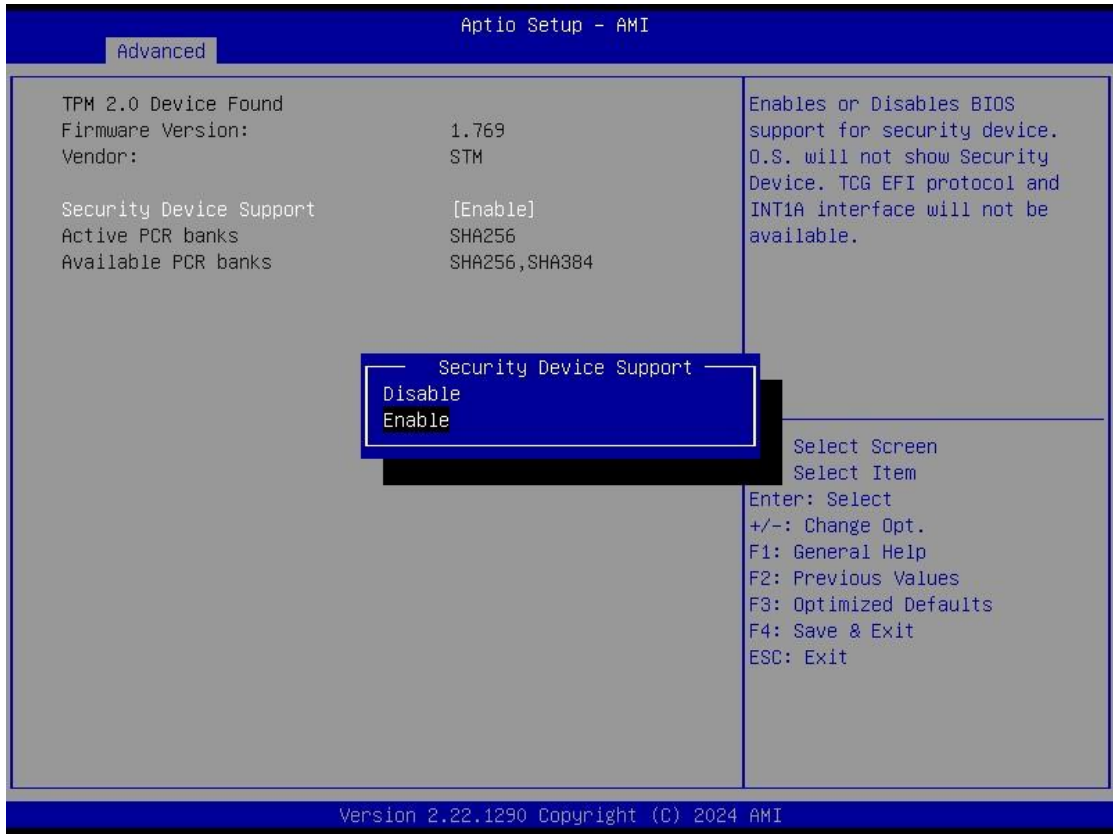

CPU Configuration

This screen shows the CPU version and its detailed information.

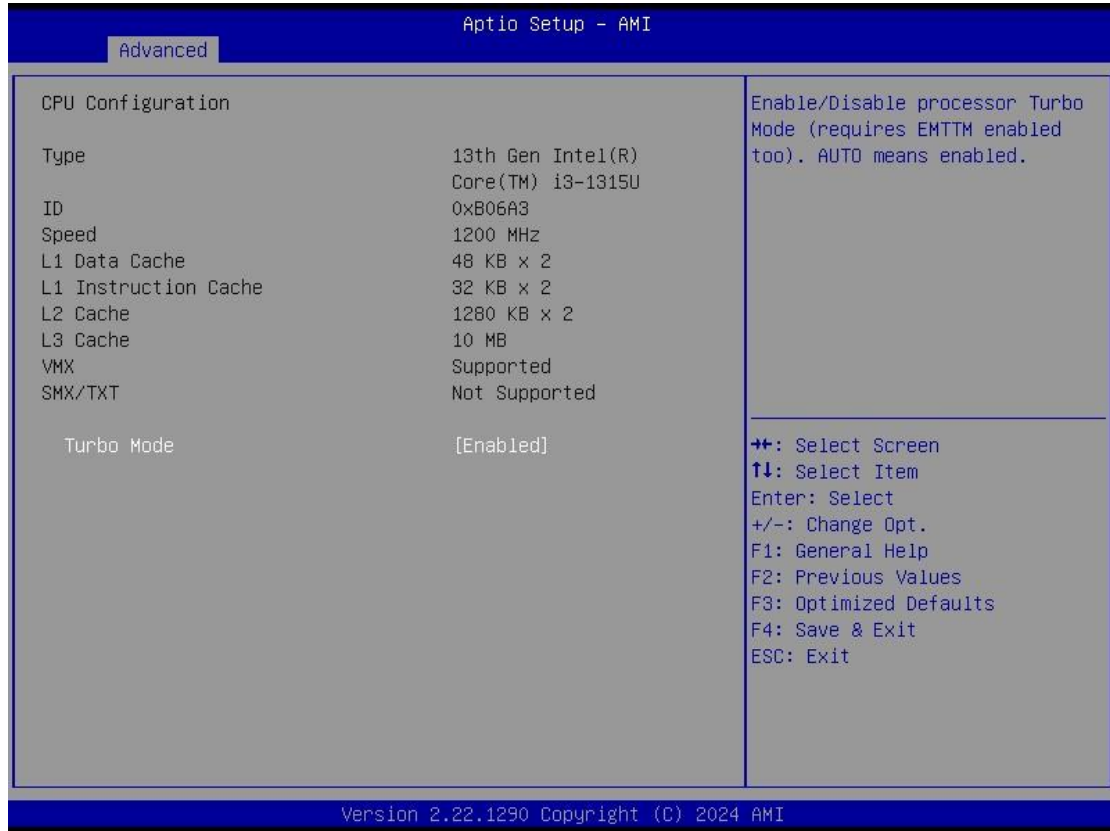

Turbo Mode

This item is for enabling or disabling turbo mode. When enabled, it allows processor cores to run faster than marked frequency under certain conditions. The default is Enabled Mode.

Storage Configuration

Users can read the current installed hardware configurations from those SATA ports in the SATA Configuration menu. During system boot up, BIOS will detect the present SATA devices automatically.

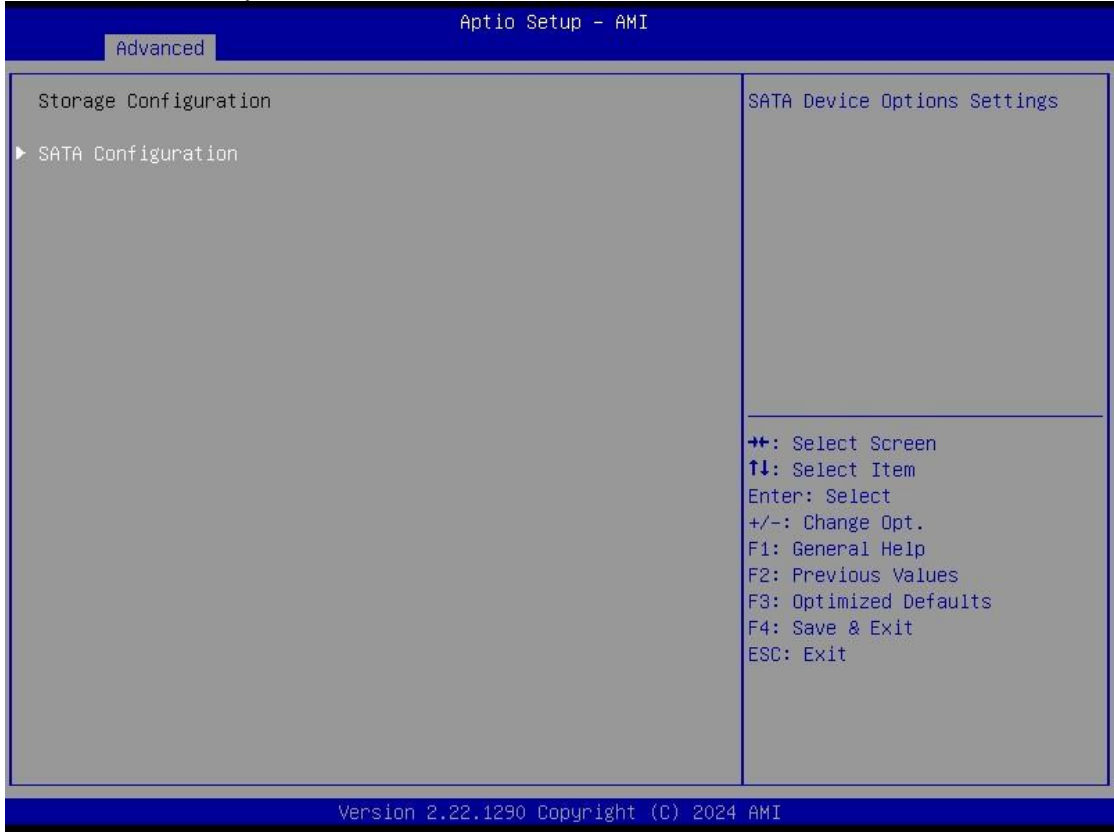

NVMe Configuration

This screen shows NVMe device information.

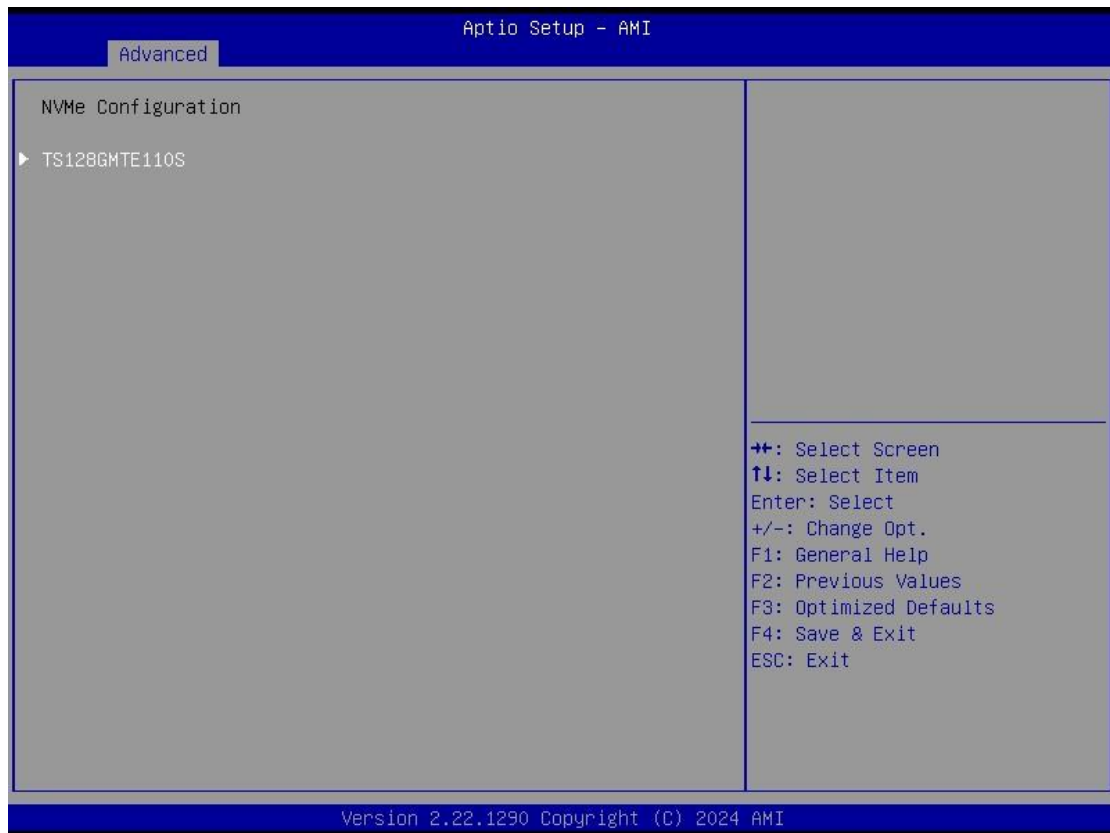

AMT Configurations

Users can use this screen to configure AMT parameters.

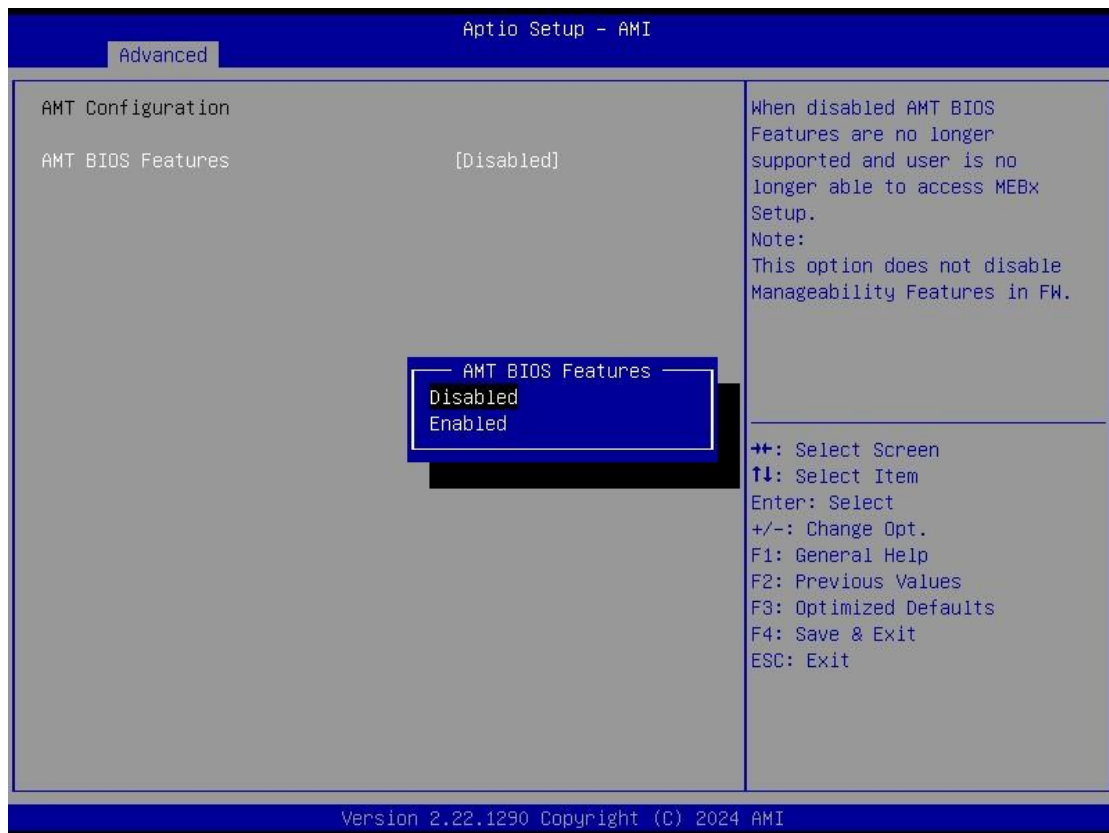

Intel® AMT

Enable or disable Intel® Active Management Technology BIOS Extension.

The default is Disabled.

F81804 Super IO Configurations

Use this screen to select options for the F81966 Super IO Configurations and change the value of the selected option. A description of the selected item appears on the right side of the screen. For items marked with “▶”, please press <Enter> for more options



Serial Port 1~2 (COM1~2) Configurations

Use these items to set parameters related to serial ports COM1~2 (RS232/422/485)

Serial Port 1

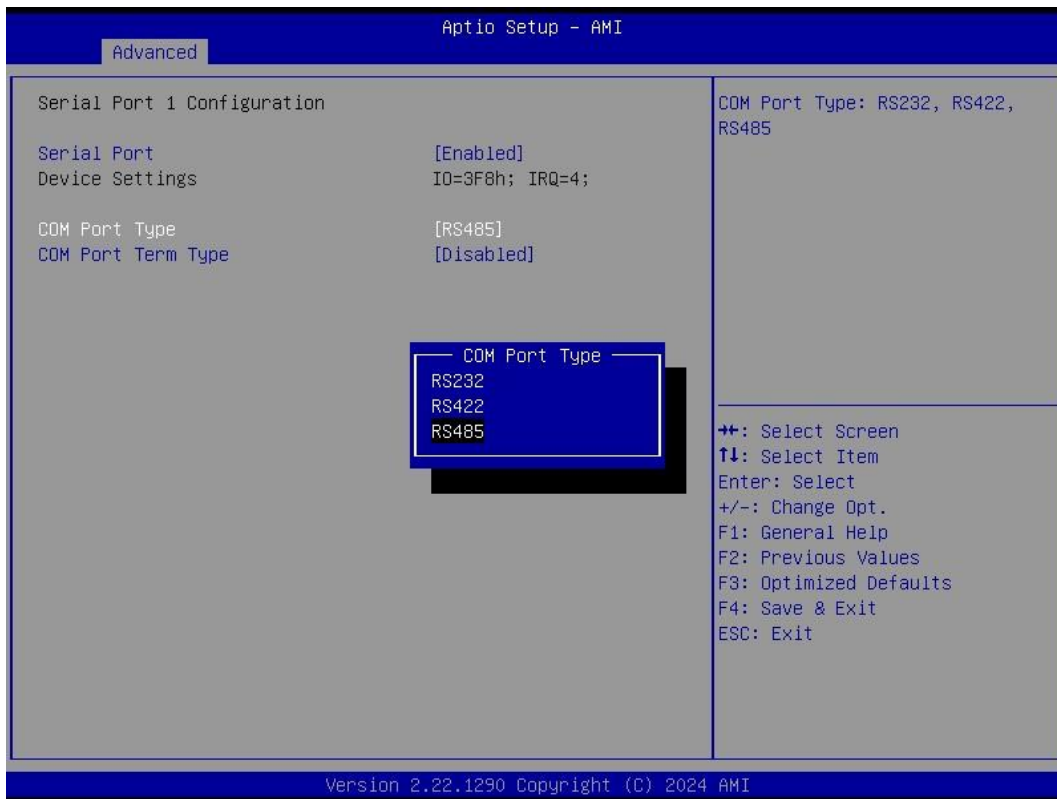

Serial Port 2

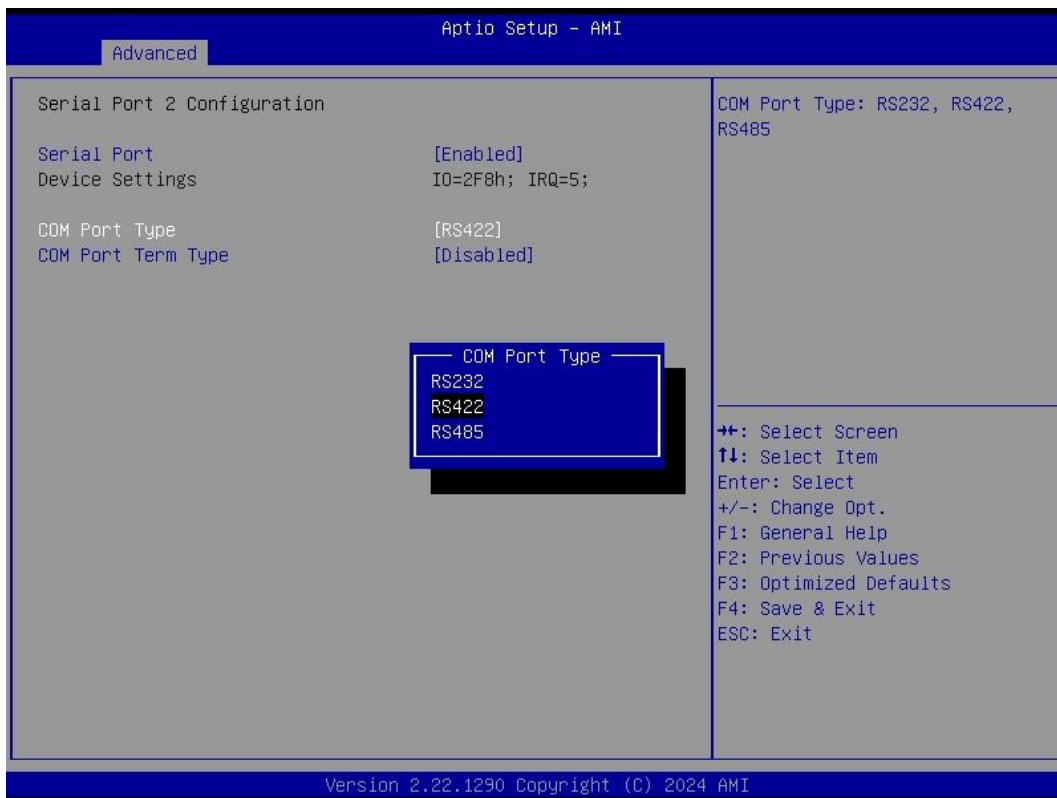

Hardware Monitor

This screen monitors hardware health status.

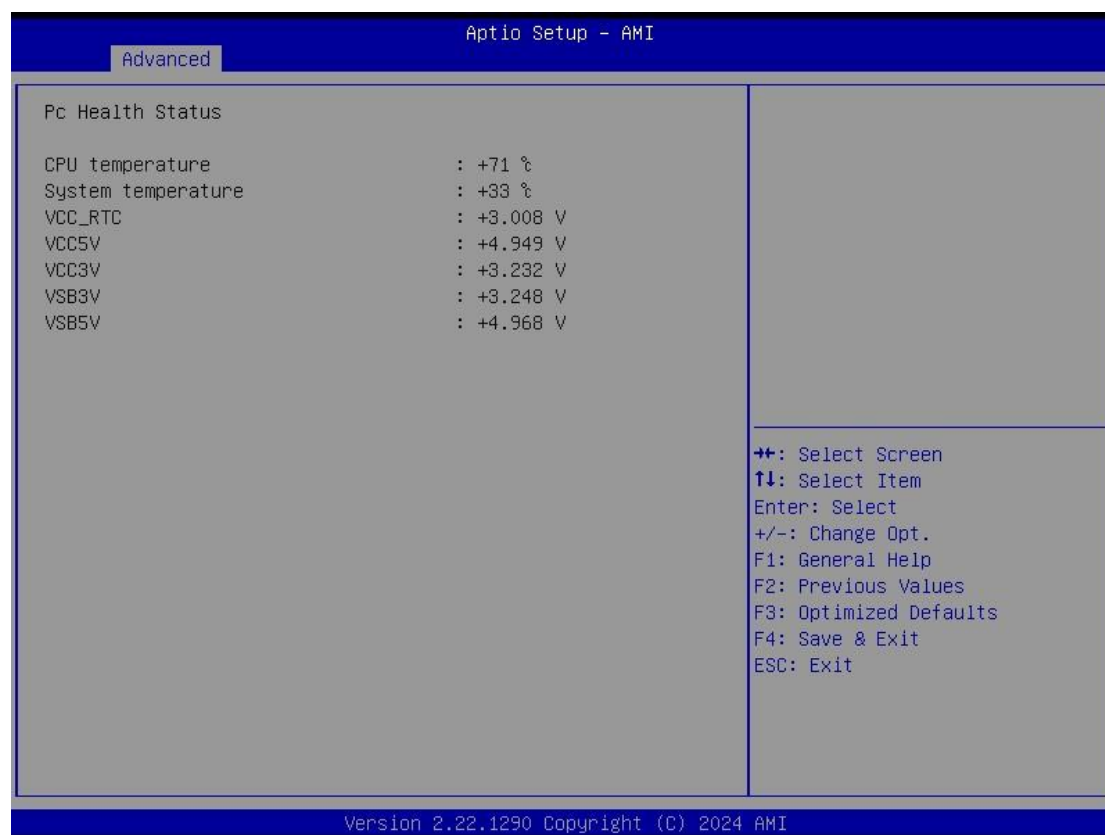

This screen displays the temperature of system and CPU as well as system voltages (VCC_RTC, +3V STBY, +5V STBY, +3V and +5V).

USB Configurations

This screen shows USB configuration.

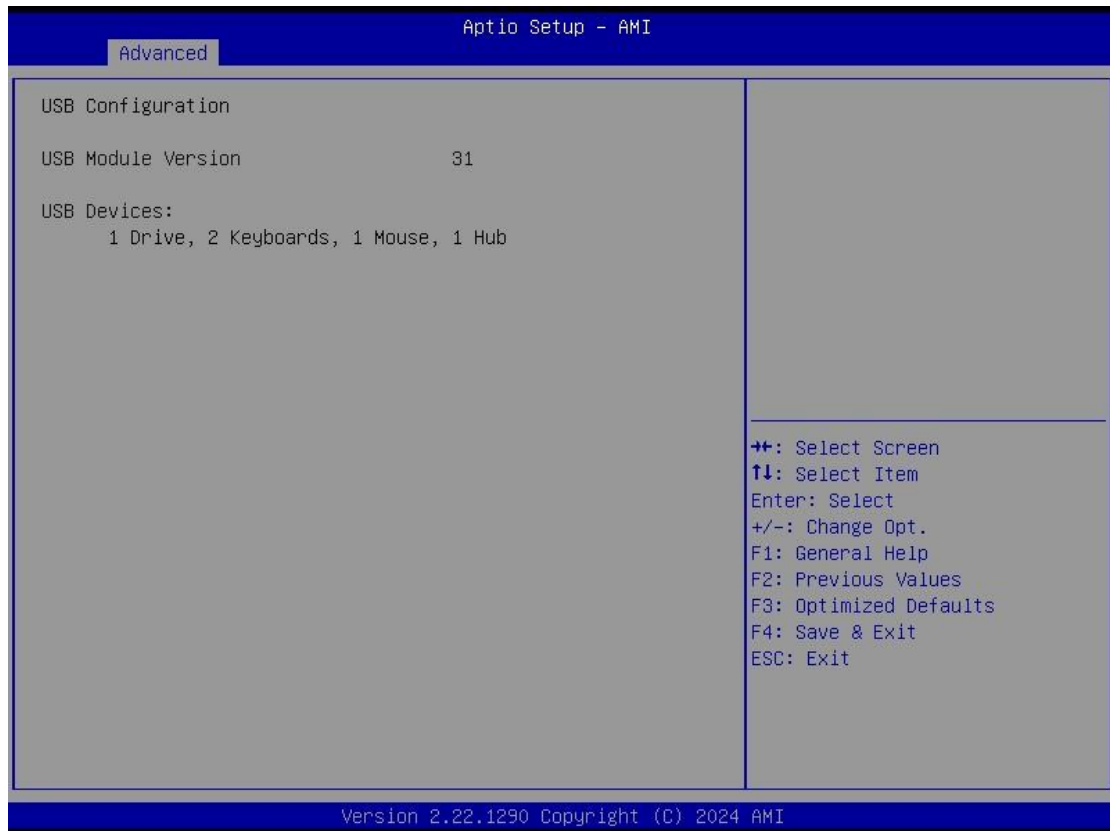

4.5 Chipset Menu

The Chipset menu allows users to change the advanced chipset settings. Users can select any of the items in the left frame of the screen to go to the sub menus:

- ▶ PCH-IO Configurations

For items marked with “▶”, please press <Enter> for more options.



PCH-IO Configurations

This screen allows users to set PCH parameters.

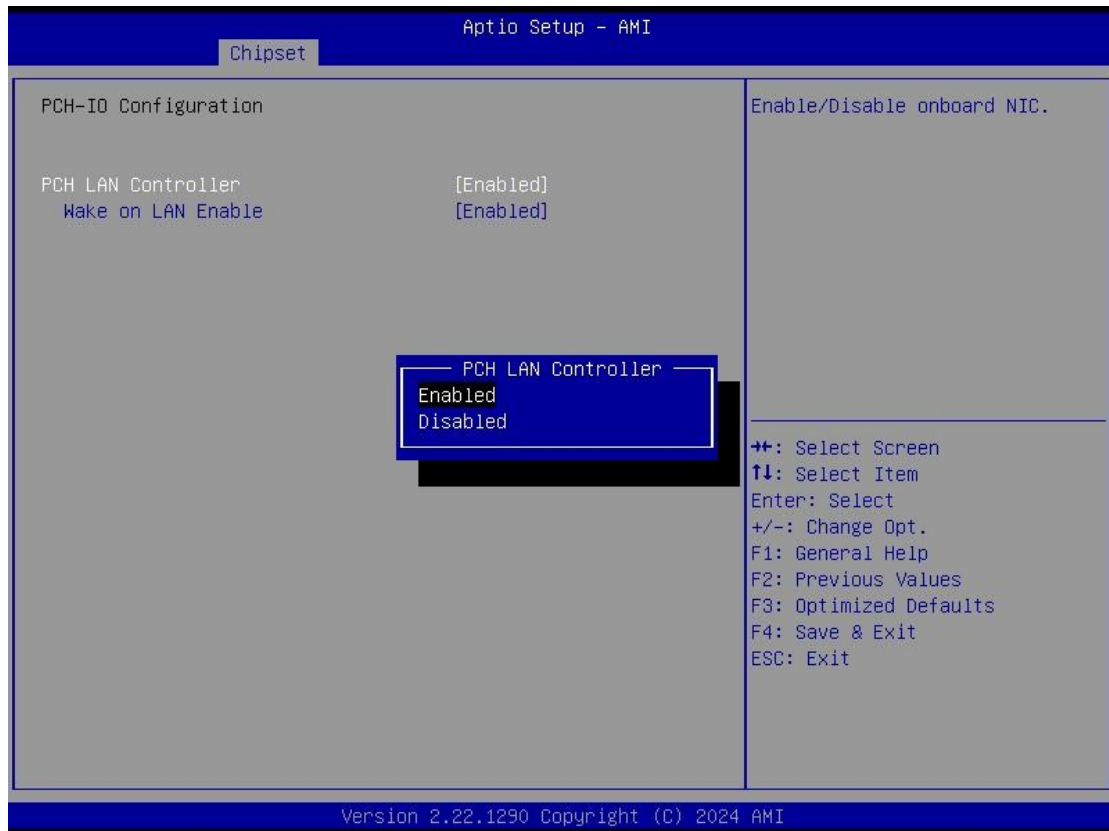

Wake on LAN Enable

Enable or disable integrated LAN to wake the system.

Security Menu

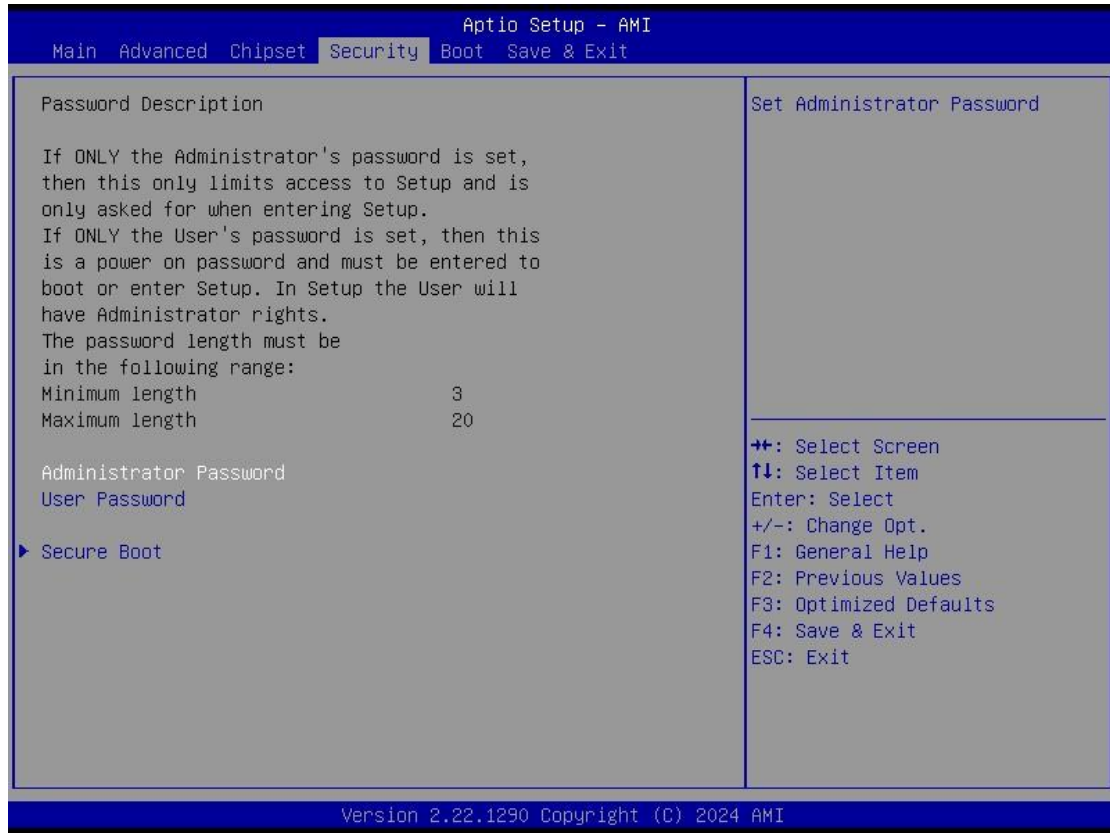

Administrator Password

This item indicates whether an administrator password has been set (installed or uninstalled).

User Password

This item indicates whether a user password has been set (installed or uninstalled).



Secure Boot Mode

Use this item to set UEFI Secure Boot Mode to Standard mode or Custommode. This change is effective after save. After reset, this mode will return to Standardmode.

Restore Factory Keys

Use this item to force System to User Mode, to install factory default SecureBoot key databases.

Reset To Setup Mode

Select Yes and press <Enter> to restore the manufacturer default Secure Boot keys. This will also reset the system to User mode. The options are Yes and No.

Key Management

Enables expert users to modify Secure boot policy variables without full authentication.

4.6 Boot Menu

The Boot menu allows users to change boot options of the system.

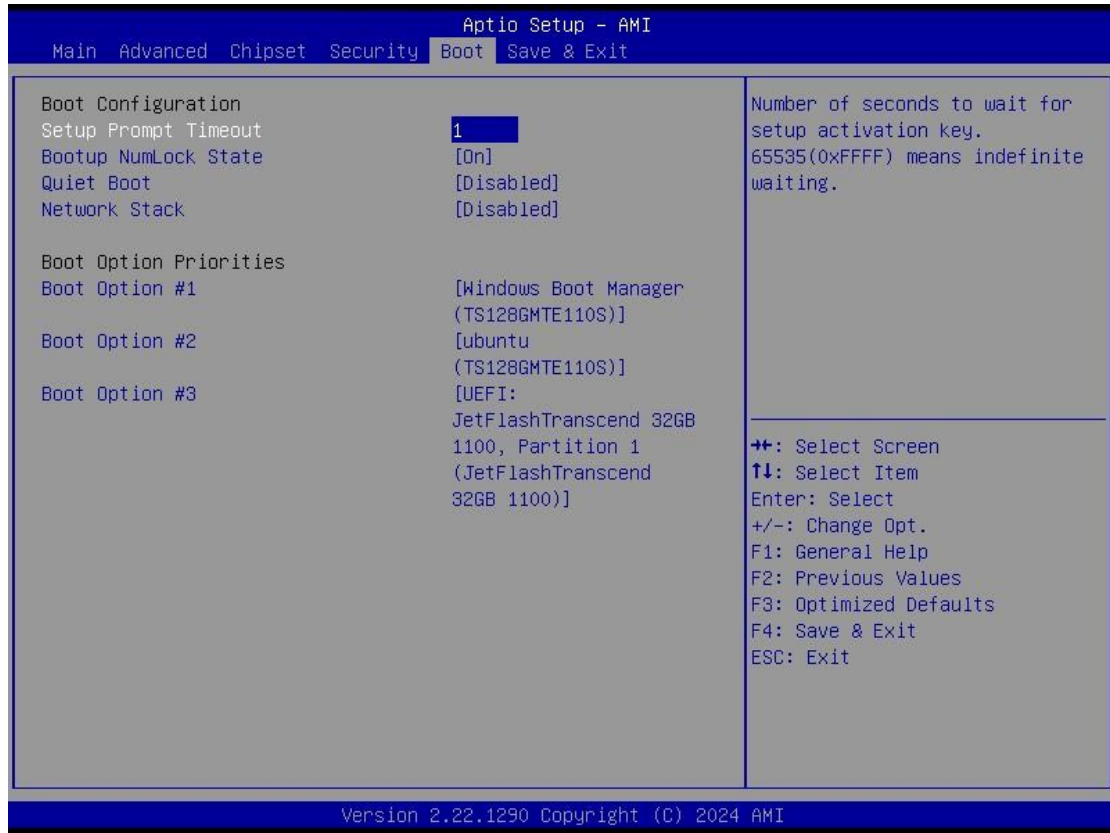

Setup Prompt Timeout

Use this item to set up number of seconds to wait for setup activation key where 65535(0xFFFF) means indefinite waiting.

Bootup NumLock State

Use this item to select the power-on state for the keyboard NumLock.

Quiet Boot

Select to display either POST output messages or a splash screen during boot-up.

Network Stack

Enable/Disable UEFI Network Stack. Default setting is Enabled.

Boot Option Priorities

These are settings for boot priority. Specify the boot device priority sequence from the available devices.

4.7 Save & Exit Menu

The Save & Exit menu allows users to load system configurations with optimal or fail-safe default values.

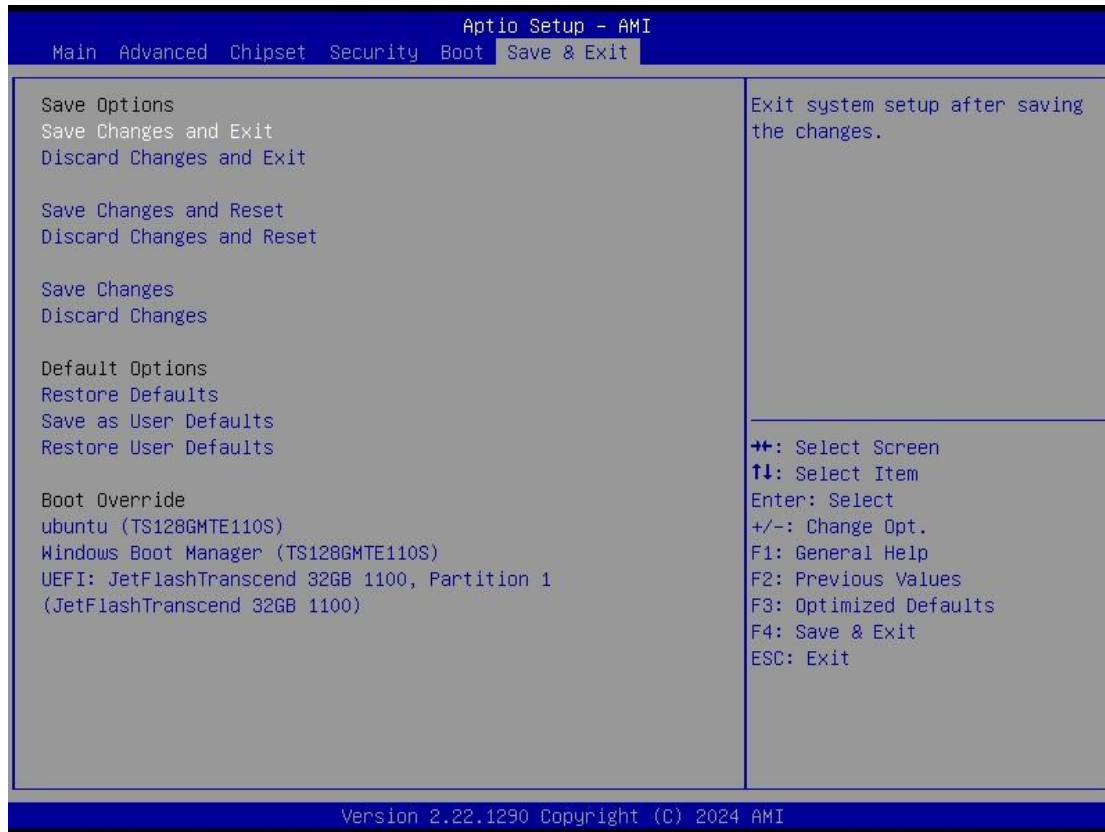

Save Changes and Exit

When users have completed the system configuration changes, select this option to leave Setup and return to Main Menu. Select Save Changes and Exit from the Save & Exit menu and press <Enter>. Select Yes to save changes and exit.

Discard Changes and Exit

Select this option to quit Setup without making any permanent changes to the system configurations and return to Main Menu. Select Discard Changes and Exit from the Save & Exit menu and press <Enter>. Select Yes to discard changes and exit.

Save Changes and Reset

Having completed the system configuration changes, select this option to leave Setup and reboot the computer so the new system configurations take effect. Select Save Changes and Reset from the Save & Exit menu and press <Enter>. Select Yes to save changes and reset.

Discard Changes and Reset

Select this option to quit Setup without making any permanent changes to the system configuration and reboot the computer. Select Discard Changes and Reset from the Save & Exit menu and press <Enter>. Select Yes to discard changes and reset.

Save Changes

Having completed the system configuration changes, select this option to save changes. Select Save Changes from the Save & Exit menu and press <Enter>. Select Yes to save changes.

Discard Changes

Select this option to quit Setup without making any permanent changes to the system configurations. Select Discard Changes from the Save & Exit menu and press <Enter>. Select Yes to discard changes.

Restore Defaults

It automatically sets all Setup options to a complete set of default settings when users select this option. Select Restore Defaults from the Save & Exit menu and press <Enter>.

Save as User Defaults

Select this option to save system configuration changes done so far as User Defaults. Select Save as User Defaults from the Save & Exit menu and press <Enter>.

Restore User Defaults

It automatically sets all Setup options to a complete set of User Defaults when users select this option. Select Restore User Defaults from the Save & Exit menu and press <Enter>.

Boot Override

Select a drive to immediately boot that device regardless of the current boot order.