

USER'S MANUAL

eBOX710A Series

Embedded System

User's Manual



www.axiomtek.com

Disclaimers

This manual has been carefully checked and believed to contain accurate information. Axiomtek Co., Ltd. assumes no responsibility for any infringements of patents or any third party's rights, or any liability arising from such uses.

Axiomtek does not warrant or assume any legal liability or responsibility for the accuracy, completeness or usefulness of any information in this document. Axiomtek does not make any commitment to update any information in this manual.

Axiomtek reserves the right to change or revise this document and/or product at any time without notice.

No part of this document may be reproduced, stored in a retrieval system, or transmitted in any forms or by any means, electronic, mechanical, photocopying, recording, among others, without prior written permissions of Axiomtek Co., Ltd.

©Copyright 2023 Axiomtek Co., Ltd.

All Rights Reserved

March 2023, Version A2

Printed in Taiwan

Safety Precautions

Before getting started, please read the following important safety precautions.

1. The eBOX710A does not come with an operating system which must be loaded first before installation of any software into the computer.
2. Be sure to ground yourself to prevent static charge when installing any internal components. Use a wrist grounding strap and place all electronic components in any static-shielded devices. Most electronic components are sensitive to static electrical charge.
3. Disconnect the power cord from the eBOX710A prior to making any installation. Be sure both the system and all external devices are turned OFF. Sudden surge of power could ruin sensitive components. Make sure the eBOX710A is properly grounded.
4. Make sure the voltage of the power source is correct before connecting it to any power outlet.
5. Turn Off system power before cleaning. Clean the system using a cloth only. Do not spray any liquid cleaner directly onto the screen.
6. Do not leave equipment in an uncontrolled environment where the storage temperature is below -40°C or above 80°C as it may damage the equipment.
7. Do not open the system's back cover. If opening the cover for maintenance is a must, only a trained technician is allowed to do so. Integrated circuits on computer boards are sensitive to static electricity. To avoid damaging chips from electrostatic discharge, observe the following precautions:
 - Before handling a board or integrated circuit, touch an unpainted portion of the system unit chassis for a few seconds. This will help discharge any static electricity on human body.
 - When handling boards and components, wear a wrist grounding strap available from most electronic component stores.
8. Caution:

Risk of explosion if battery is replaced by an incorrect type Dispose of used batteries according to the instructions.

IL Y A RISQUE D'EXPLOSION SI LA BATTERIE EST
REPLACEE
PER UNE BATTERIE DE TYPE INCORRECT.
METTRE AU REBUT LES BATTERIES USAGEES
CONFORMEMENT AUX INSTRUCTIONS
9. Warning:

Hot Surface Do Not Touch.

Restricted access locations: The equipment should only be installed in a Restricted Access Area.

Classifications

1. Degree of protection against electric shock: not classified
2. Degree of protection against ingress of water: IP40
3. Equipment not suitable for use in the presence of a flammable anesthetic mixture with air, oxygen or nitrous oxide.
4. Mode of operation: Continuous

General Cleaning Tips

Please keep the following precautions in mind while understanding the details fully before and during any cleaning of the computer and any components within.

A piece of dry cloth is ideal to clean the device.

1. Be cautious of any tiny removable components when using a vacuum cleaner to absorb dirt on the floor.
2. Turn the system off before cleaning up the computer or any components within.
3. Avoid dropping any components inside the computer or getting circuit board damp or wet.
4. For cleaning, be cautious of all kinds of cleaning solvents or chemicals which may cause allergy to certain individuals.
5. Keep foods, drinks or cigarettes away from the computer.

Cleaning Tools:

Although many companies have created products to help improve the process of cleaning computer and peripherals, users can also use house hold items accordingly for cleaning. Listed below are items available for cleaning computer or computer peripherals.

Pay special attention to components requiring designated products for cleaning as mentioned below.

- Cloth: A piece of cloth is the best tool to use when rubbing up a component. Although paper towels or tissues can be used on most hardware as well, it is recommended to use a piece of cloth.
- Water or rubbing alcohol: A piece of cloth may be somewhat moistened with water or rubbing alcohol before being rubbed on the computer. Unknown solvents may be harmful to plastic parts.
- Absorb dust, dirt, hair, cigarette and other particles outside of a computer can be one of the best methods of cleaning a computer. Over time these items may restrict the airflow in a computer and cause circuitry to corrode.
- Cotton swabs: Cotton swaps moistened with rubbing alcohol or water are applicable to reach areas in keyboard, mouse and other areas.
- Foam swabs: If possible, it is better to use lint free swabs such as foam swabs.



【Note】 : *It is strongly recommended that customer should shut down the system before starting to clean any single components.*

Please follow the steps below:

1. Close all application programs.
2. Close operating software.
3. Turn off power switch.
4. Remove all devices.
5. Pull out power cable.

Scrap Computer Recycling

Please inform the nearest Axiomtek distributor as soon as possible for suitable solutions in case computers require maintenance or repair; or for recycling in case computers are out of order.

Trademarks Acknowledgments

Axiomtek is a trademark of Axiomtek Co., Ltd.

IBM, PC/AT, PS/2, VGA are trademarks of International Business Machines Corporation. Intel® and Pentium® are registered trademarks of Intel Corporation.

MS-DOS, Microsoft C and QuickBasic, Windows 10, Windows 8.1, Windows 8, Windows 7, Windows XPE, Windows XP, Windows CE embedded, Linux are trademarks of Microsoft Corporation.

Other brand names and trademarks are the properties and registered brands of their respective owners.

Table of Contents

Disclaimers.....	ii
Safety Precautions.....	iii
Classifications.....	iv
General Cleaning Tips	v
Scrap Computer Recycling.....	vi
SECTION 1 INTRODUCTION.....	1
1.1 General Descriptions	1
1.2 System Specifications	3
1.2.1 CPU	3
1.2.2 I/O System	3
1.2.3 System Specifications.....	4
1.2.4 Driver CD Contents.....	5
1.3 Dimensions	6
1.3.1 System Dimensions.....	6
1.3.2 Wall-mount Bracket Dimensions	7
1.3.3 Din-Rail Bracket Dimensions.....	9
1.4 I/O Outlets.....	11
1.5 Packing List.....	13
1.6 Model List	13
SECTION 2 HARDWARE INSTALLATION	15
2.1 Installation of CPU	15
2.2 Installation of 2.5" SATA Device	18
2.3 Installation of M.2 Mini PCIe Module (CN26)	19
2.4 Installation of Mini PCIe Module (Full-size)(CN17,CN20).....	20
SECTION 3 JUMPER & CONNECTOR SETTINGS.....	21
3.1 Locations of Jumpers & Connectors.....	21
3.2 Summary of Jumper Settings.....	23
3.2.1 Restore BIOS Optimal Defaults (JP1)	23
3.3 Connectors	24
3.3.1 DC-in Phoenix Power Connector (CN1).....	25
3.3.2 HDMI Connector (CN7, CN8).....	25
3.3.3 DisplayPort Connector (CN4)	26
3.3.4 Serial Port Connector (CN3)(CN18)(CN21).....	26
3.3.5 USB 3.2 Connector (CN5, CN6, CN30)	27
3.3.6 Ethernet Connector (LAN1~LAN4).....	28
3.3.7 ATX Power On/Off (SW1)	28
3.3.8 ATX Power on/off (SW2).....	28
3.3.9 Remote Power Switch Connector (PWRBT1)	29
3.3.10 ATX/AT Quick Switch	29
3.3.11 SATA Connector (SATA1 & 2).....	29
3.3.12 SATA Power Connector (CN10,CN11).....	30
3.3.13 SIM Card Slots (SCN1, CN22).....	30
3.3.14 Full-Size PCI Express Mini Card Slot (CN17,CN20)	31
3.3.15 M.2 3050/3052 Key B slot (CN26)	33
3.3.16 Intel® HD Audio Digital Header (CN31, CN32)(Optional)	34
3.3.17 Digital I/O (CN14 and CN16) (optional).....	34
SECTION 4 BIOS SETUP UTILITY	35

4.1	Starting	35
4.2	Navigation Keys.....	35
4.3	Main Menu	36
4.4	Advanced Menu	37
4.5	Chipset Menu	51
4.6	Boot Menu	56
4.7	Save & Exit Menu	57
APPENDIX A WATCHDOG TIMER		59
A.1	About Watchdog Timer.....	59
A.2	Sample Program	59

SECTION 1 INTRODUCTION



This section contains general information and detailed specifications of the eBOX710A. Section 1 consists of the following sub-sections:

- General Descriptions
- System Specifications
- Dimensions
- I/O Outlets
- Packing List
- Model List

1.1 General Descriptions

The eBOX710A is a high-performance GPU computing fanless embedded system that features the 10th/11th generation Intel® Core™ i9/i7/i5/i3 & Celeron® with Intel® H420E chipset. It comes with an IP40-rated heavy-duty aluminum extrusion design, offers 9-48V DC power input with power protection, and supports -40°C to +70°C extended temperature range*, thus enabling reliable operation in harsh environments.

To minimize deployment time, eBOX710A supports one flexible I/O window for customers to easily install additional I/O output. It also supports multiple I/O connections including 6 USB 3.2 ports, 4 COM ports, plus 2 SIM slots are provided for remarkable mobile availability. It is making perfectly suitable for intelligent factory, machine vision, edge computing, deep learning platform, objective identification, or related objective classification applications.

Features

- LGA1200 10th/11th gen Intel® Core™ i9/i7/i5/i3 or Celeron® with Intel® H420E chipset (Comet Lake-S)
- Dual 2.5" SATA HDD drive bays
- 2 HDMI and 1 DisplayPort for dual view
- TPM 2.0 onboard
- -40 °C to +70 °C wide range operation temperature
- Wide range power input 9-48VDC
- Supports PCIe x4 slot
- Flexible I/O Window supported via various mPCIe modules

Reliable and Stable Design

The embedded system supports 10th/11th generation Intel® Core™ i7/i5/i3 and Celeron® 35 or 65 watt processors, along with high flexibility and multi-functional design that make it the best solution for smart factory applications.

Flexible Connectivity

The eBOX710A comes with rich I/O interfaces including two RS-232/422/485 ports, two RS-232, six USB 3.2 ports, four GbE ports, two HDMI, one DisplayPort, flexible I/O window and one PCIe x4 expansion slot supported.

Embedded O.S. Supported

The eBOX710A with 10th/11th generation platform supports Windows® 10/11, Windows® 10/11 IoT and Linux.

Various Storage Supported

In terms of storage, the eBOX710A supports two 2.5" SATA storage drive bay and two mSATA devices.

1.2 System Specifications

1.2.1 CPU

- **CPU (10th gen, 35W/65W)**
 - LGA1200 10th/11th gen Intel® Core™ i9/i7/i5/i3 & Celeron® processors
 - Intel® Core™ i9-10900T Processor (35W)
 - Intel® Core™ i7-10700 (65W)
 - Intel® Core™ i7-10700E (65W)
 - Intel® Core™ i5-10500E (65W)
 - Intel® Core™ i3-10100E (65W)

- **CPU (11th gen, 35W/65W)**
 - Intel® Core™ i5-11500 (65W)

- **Chipset**
 - Intel® H420E

- **BIOS**
 - American Megatrends Inc. UEFI (Unified Extensible Firmware Interface) BIOS.

- **System Memory**
 - 2 x 260-pin DDR4-2933 non-ECC SO-DIMM, up to 64GB

1.2.2 I/O System

- **Display**
 - 2 x lockable HDMI 1.4b (Resolution: 4096x2160@30Hz)
 - 1 x DisplayPort 1.2++ (Resolution: 4096x2304@60Hz)

- **Ethernet**
 - 4 x 10/100/1000 Ethernet ports (3 x i210IT & 1 x i219LM)(support UEFI PXE)

- **USB Ports**
 - 5 x USB 3.2 Gen 1
 - 1 x USB 2.0

- **Serial Ports**
 - 2 x RS-232 (COM 3~4)
 - 2 x RS-232/422/485 (COM1~2, by BIOS setting page 40-42)

- **Mini PCIe Interface**
 - 2 x full-size PCI Express Mini Card Slots (USB + PCI Express + SATA signal)

- **Storage**
 - 2 x 2.5" swappable SATA HDD/SSD drive bay, up to 9.5mm height
 - 2 x mSATA (enabled in BIOS setting)

- **Flexible I/O Window**
 - Default : 2 x DB9 half cut bracket

- **Expansion**
 - PCIe x4 slot

- **Indicator**
 - 1 x Green LED as indicator for PWR status
 - 1 x Orange LED as indicator for HDD active
 - 4 x Green LED as indicator for programmable

- **Switch**
 - 1 x ATX PWR switch
 - 1 x Remote PWR switch
 - 1 x ATX/AT Quick switch
 - 1 x Reset switch

- **Antenna & SIM**
 - 5 x SMA type connector openings for antenna
 - 1 x front access SIM slot for M.2

- **TPM 2.0**
 - 1 x ST33HTPH2E32AHA6

1.2.3 System Specifications

- **Watchdog Timer**
 - 1~255 seconds or minutes; up to 255 levels.

- **Power Supply**
 - 9-48V DC input

- **Operation Temperature**
 - -40°C to 70°C (-40°F to +158°F) (with W.T. DRAM & SSD,CPU TDP 35W)
 - -40°C to 60°C (-40°F to +140°F) (with W.T. DRAM & SSD,CPU TDP 65W)

- **Storage Temperature**
 - -40°C ~+80°C (-40 °F ~ 176°F)

- **Humidity**
 - 10% ~ 95% (non-condensation)

- **Shock**
 - IEC 60068-2-27 (w/SSD: 50G@wall mount, half sine,11 ms duration)

- **Vibration Endurance**
 - IEC 60068-2-64 (w/SSD: 3Grms STD, random, 5 - 500 Hz,1 hr/axis)

- **Weight**
 - 4.9 kg (10.8 lb) without package
 - 7 kg (15.43 lb) with package

- **Dimension**
 - 280 mm (11.02") (W) x 210 mm (8.26") (D) x 80.5 mm (3.16") (H)

1.2.4 Driver CD Contents

Please download the following eBOX710A drivers from the Axiomtek official website.

- Ethernet
- Chipset
- Graphic
- Serial Port
- USB 3.2
- Intel® ME
- Audio (optional)



【Note】 : *All specifications and images are subject to change without notice.*

1.3 Dimensions

The following diagrams show dimensions and outlines of the eBOX710A.

1.3.1 System Dimensions

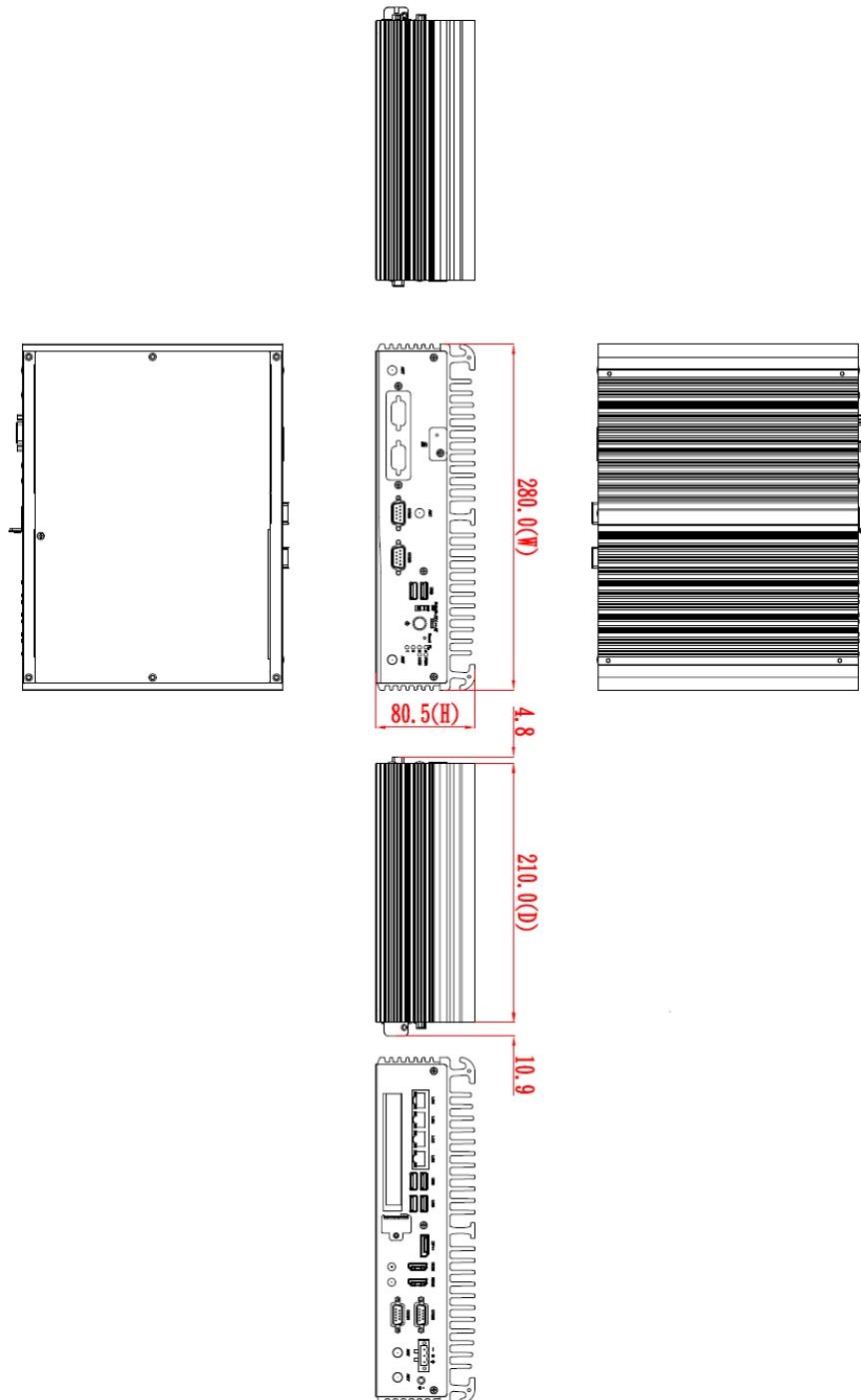

1.3.2 Wall-mount Bracket Dimensions

Users can get 6pcs truss head M3*6L screws for fixing the wall mount kit from the accessories box.

Note: When users install wall mount kit, please turn the LAN ports side outlet towards the floor.

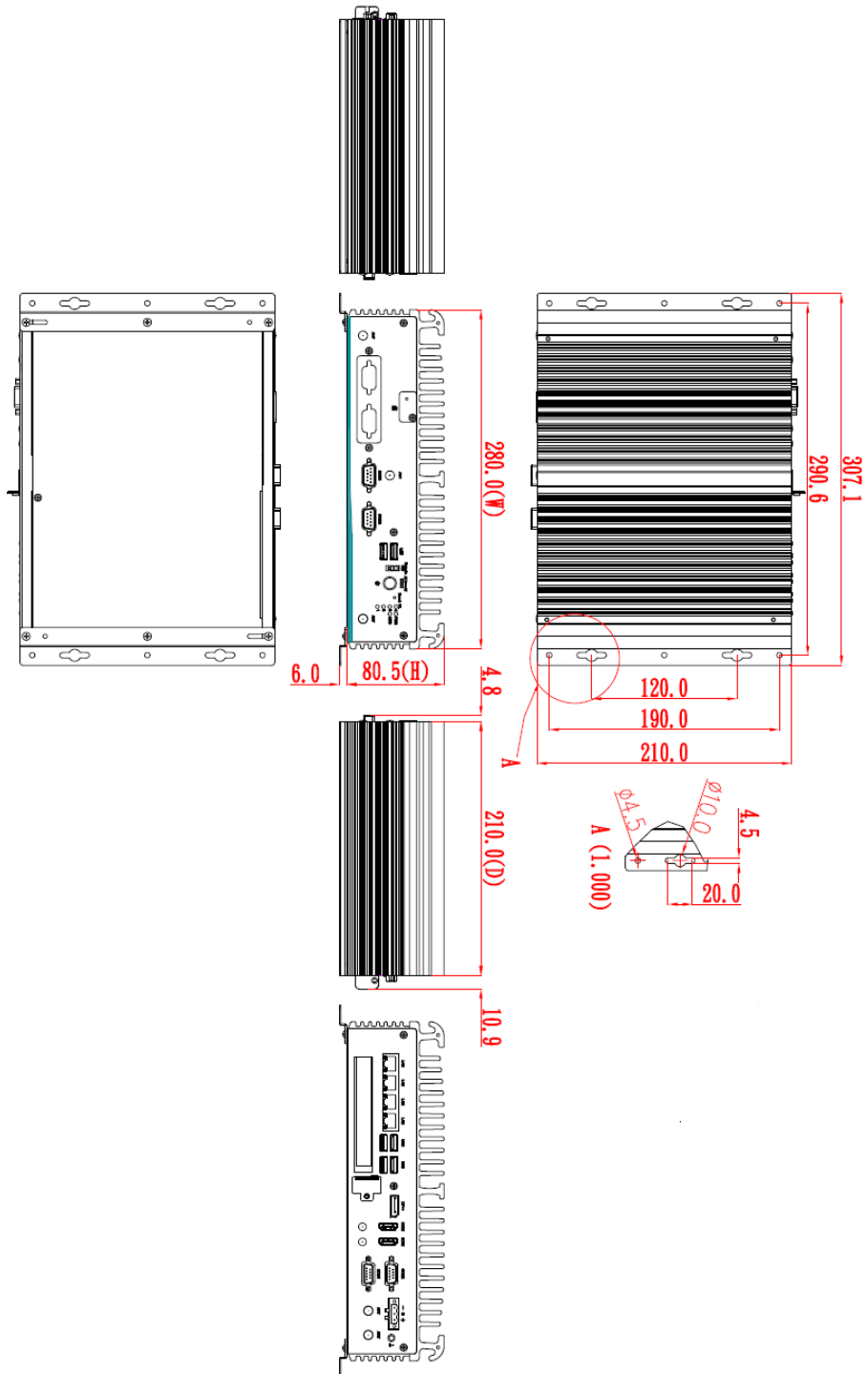

Wall-mount Bracket Assembly Drawing

Users can get 6pcs truss head M3*6L screws for fixing the wall mount kit from the accessories box.

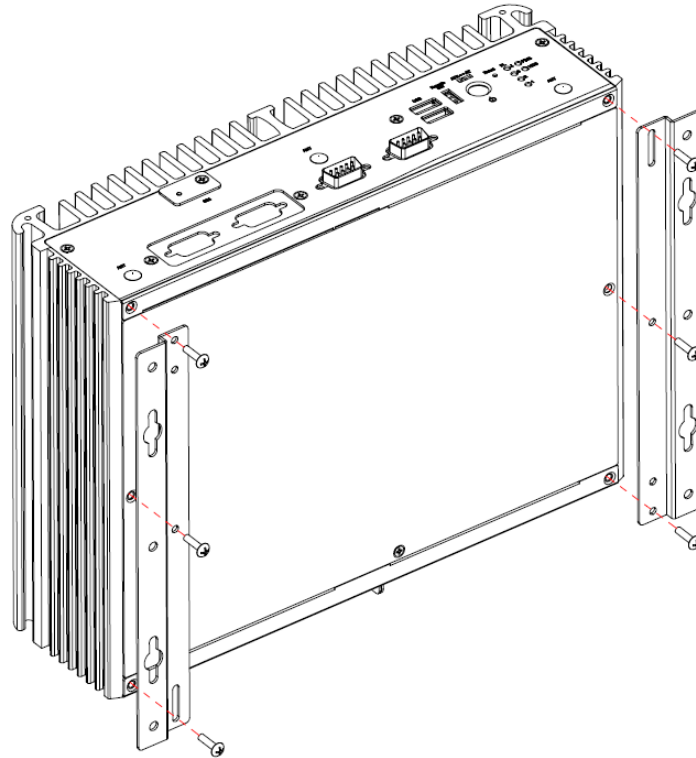

【Note】 : If users install the screws in drywall, use the hollow wall anchors to ensure that unit does not pull away from the wall due to prolonged strain between the cable and power connector.

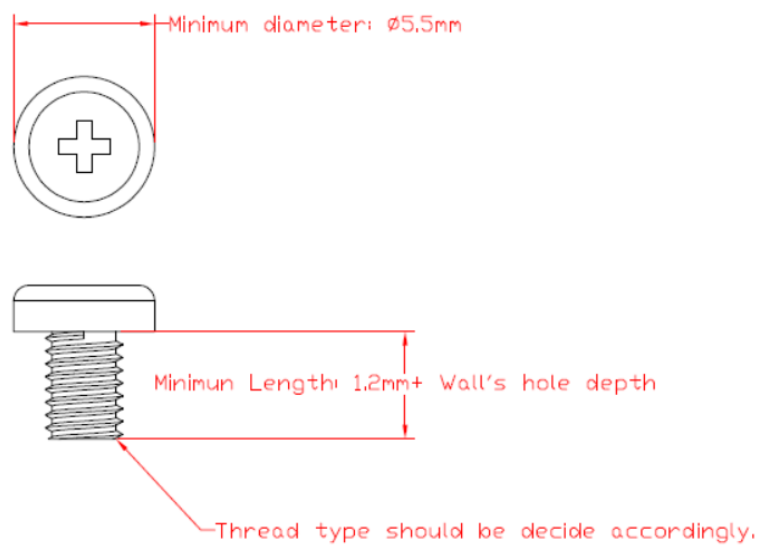

1.3.3 Din-Rail Bracket Dimensions

Users can get 6pcs truss head M3*6L screws for fixing the wall mount kit from the accessory box.

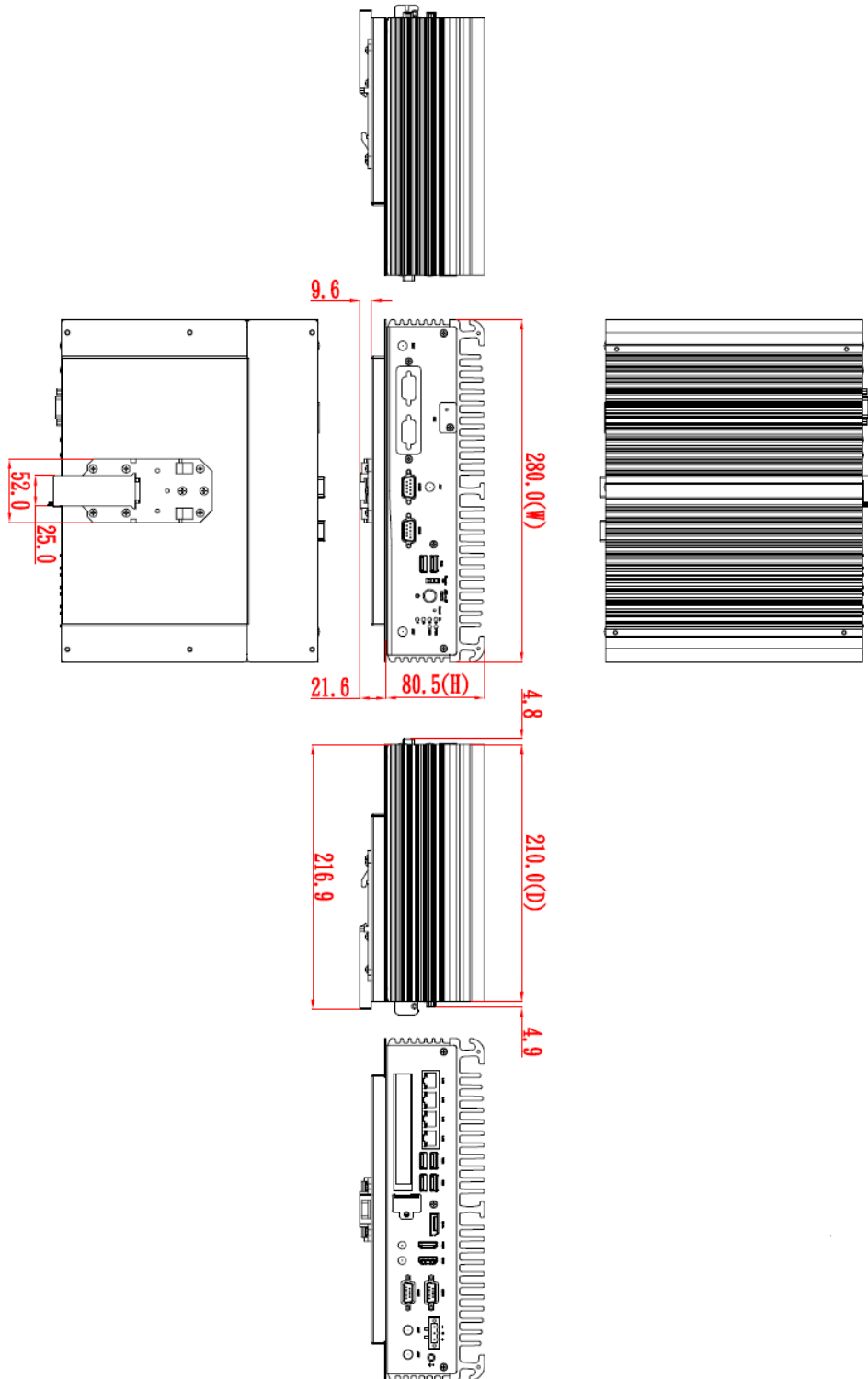

Din-Rail Bracket Assembly Drawing

Users can get 6pcs truss head M3*6L screws for fixing the wall mount kit from the accessory box.

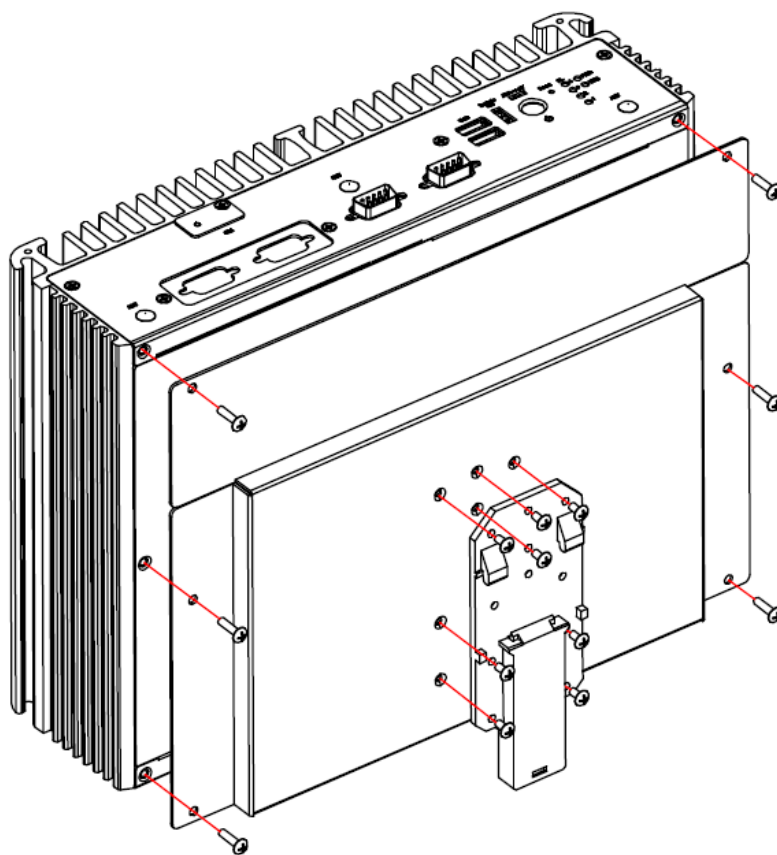

1.4 I/O Outlets

The following figures show I/O outlets on the eBOX710A.

Front View

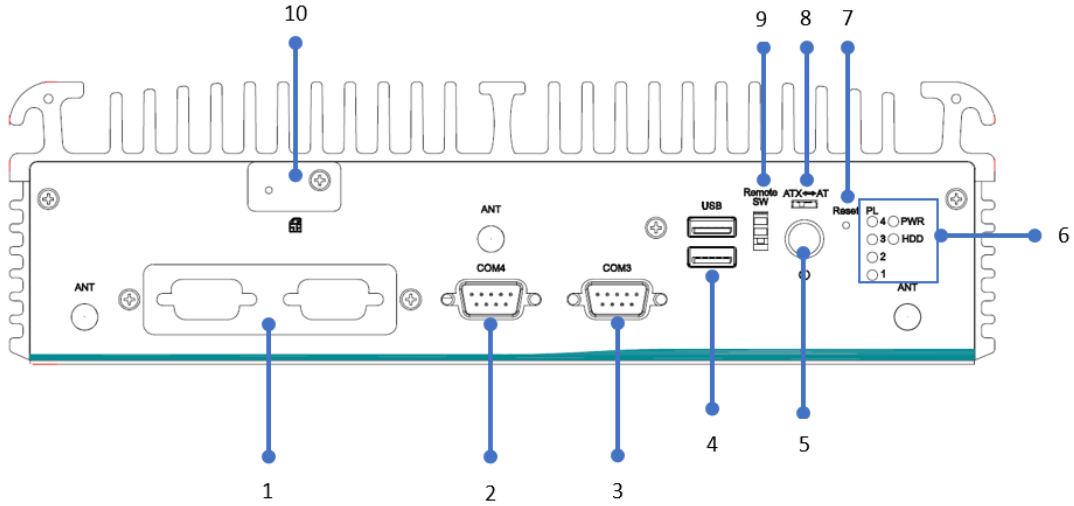

1	1 x Flexible IO window	6	LEDs
2	RS232(COM4)	7	1 x Reset switch
3	RS232(COM3)	8	1 x ATX/AT quick switch
4	2 x USB 3.2 Gen 1	9	1 x Remote switch
5	1 x Power botton	10	1 x front access SIM slot

Rear View

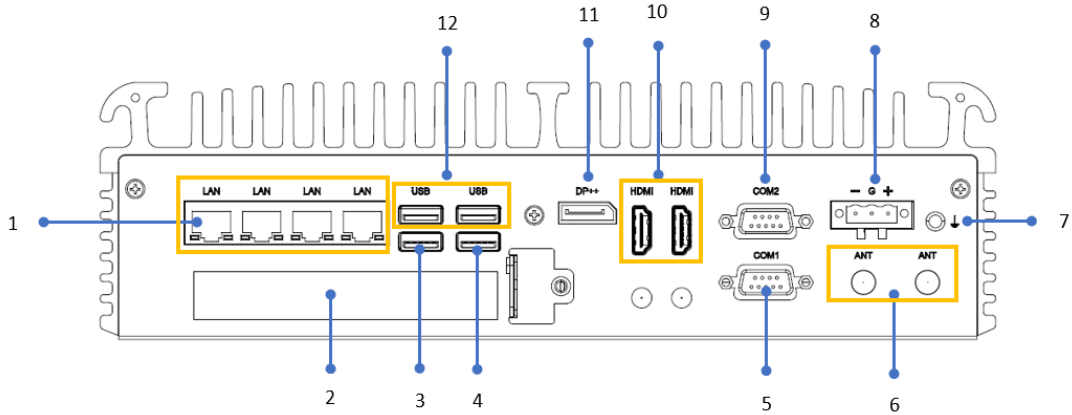

1	4 x GbE LAN	7	1 x Grounding screw
2	PCIe x4 expansion slot	8	1 x Phoenix type power connector (9-48VDC)
3	1 x USB 2.0	9	1 x RS232/422/485 (COM2)
4	1 x USB 3.2 Gen 1	10	2 x HDMI
5	1 x RS232/422/485 (COM1)	11	1 x DisplayPort
6	2 x Antenna opening	12	2 x USB 3.2 Gen 1

1.5 Packing List

The eBOX710A comes with the following bundle package:

- eBOX710A System Unit x 1
- Thermal Grease x 1
- 3-pin Terminal Block connector x 1
- Remote Switch Cable x 1
- Foot Pad x 4
- HDD bracket x 2 + screws
- M.2 bracket x 1 + thermal pad x 2 + screws

1.6 Model List

eBOX710A-CML-PCIe	Fanless Embedded System with LGA1200 Socket 10th/11th Gen Intel® Core™ i9/i7/i5/ i3 or Celeron® Processor, Intel® H420E, 2 HDMI, 1 DisplayPort, 6 USB, 4 LAN, PCIe x4 expansion slot and 9 to 48 VDC
-------------------	--

Please contact Axiomtek's distributors immediately in case any abovementioned items are missing.

This page is intentionally left blank.

SECTION 2 HARDWARE INSTALLATION

The eBOX710A is convenient for various hardware configurations, such as CPU, DRAM, HDD (Hard Disk Drive), SSD (Solid State Drive), PCI Express Mini card modules . Section 2 contains guidelines for hardware installation.

2.1 Installation of CPU

Step 1 Turn off the system and unplug the power cord.

Step 2 Loosen four screws to remove top cover.

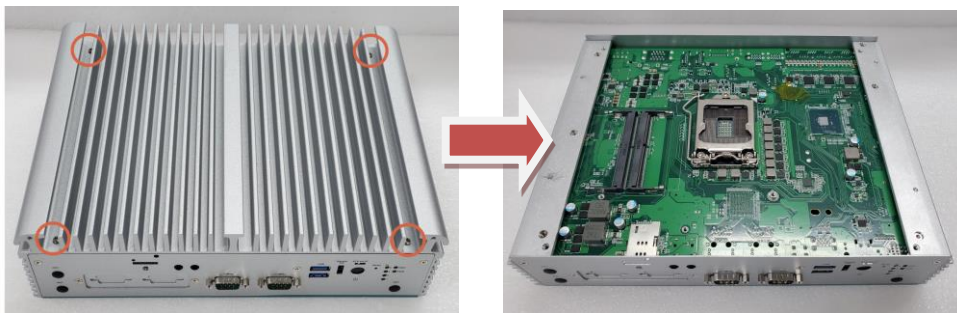

Step 3 Remove the warning label and disengage load lever.

- Disengage load lever by pushing its hook down and then pulling it slightly outward.
- Rotate load lever to open position at approximately 135°.
- Rotate load plate to open position at approximately 150°.



【Note】 : Apply pressure to corner with right-hand thumb when opening or closing load lever - otherwise lever will bounce back (as a mouse trap) causing bent contacts.

Step 4 CPU installation steps:

- Lift processor package from shipping media by grasping the substrate edges.



- Scan the processor package gold pads for any presence of foreign material.
- Locate connection 1 indicator on the processor which aligns with connection 1 indicator chamfer on the socket, and notice processor keying features that line up with posts along socket walls.
- Grasp the processor with thumb and index finger along the top and bottom edges. The socket will have cutouts for your fingers to fit into.
- Carefully place the processor into the socket body vertically.

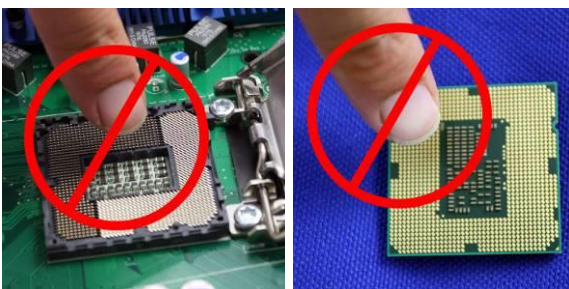
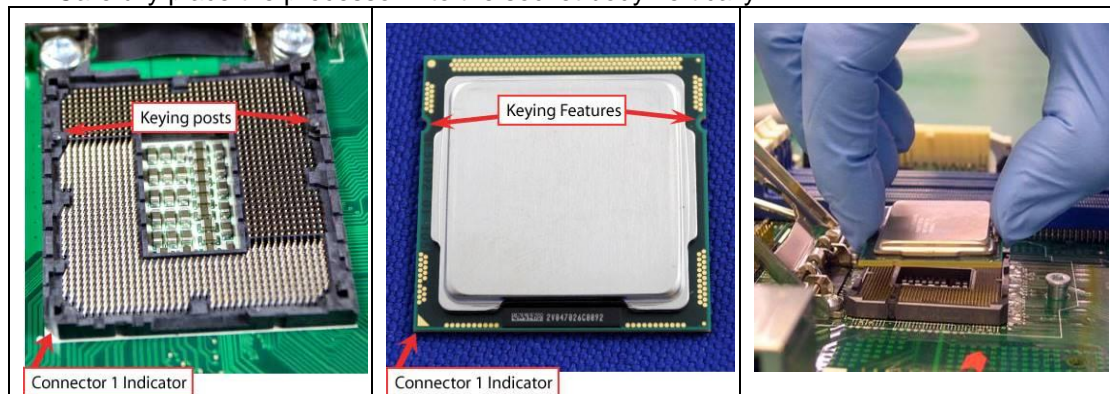

【Note】 : Never touch fragile socket contacts to avoid damage and do not touch the processors sensitive contacts at any time during installation.

Step 5 Align pins of the CPU with pin holes of the socket. While installing the CPU, pay attention to the CPU's orientation by aligning the arrow mark on the CPU with the arrow key on the socket.

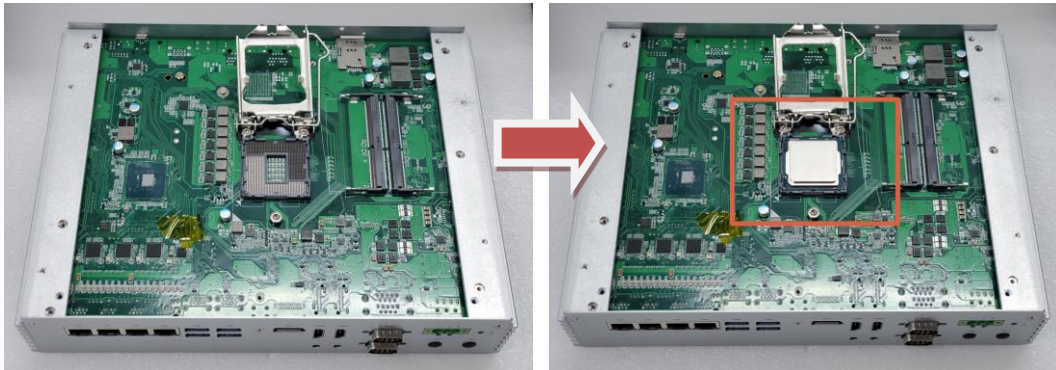

Step 6 Put the top cover and fasten four screws back onto the system.

2.2 Installation of 2.5" SATA Device

Step 1 Turn off the system and unplug the power cord.

Step 2 Loosen three screws to remove bottom cover and Locate two SSD/HDD within the red line as marked.

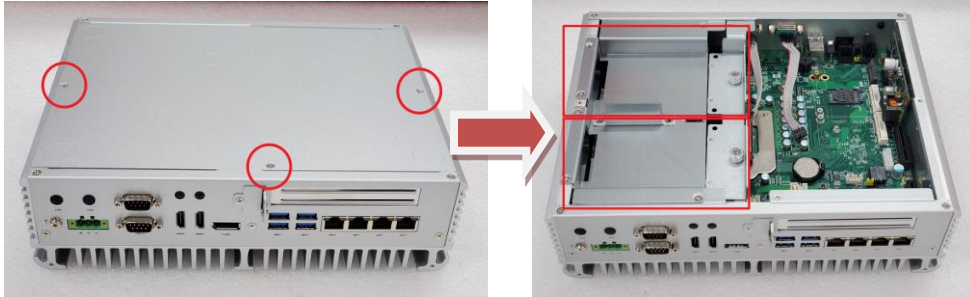

Step 3 Assembly each SSD/HDD with the HDD bracket with 2 screws.

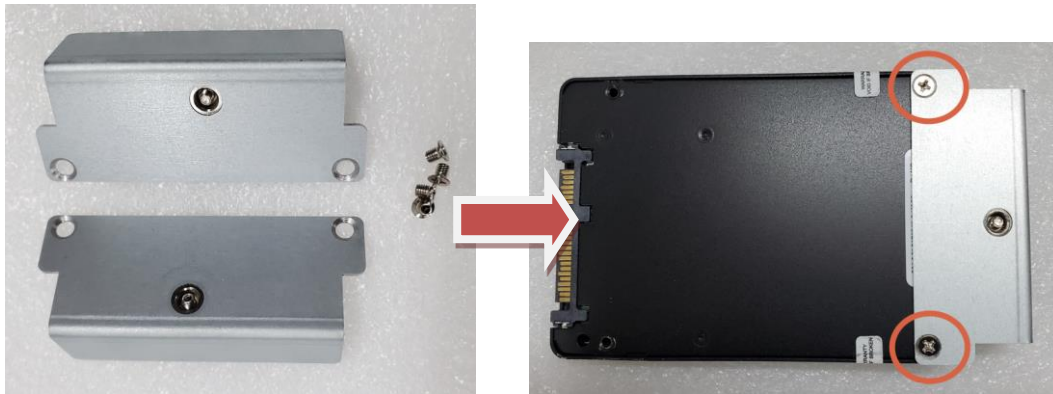

Step 4 Push the SATA drive tray to insert the connector firmly and fasten the screw to make sure the insertion is complete.

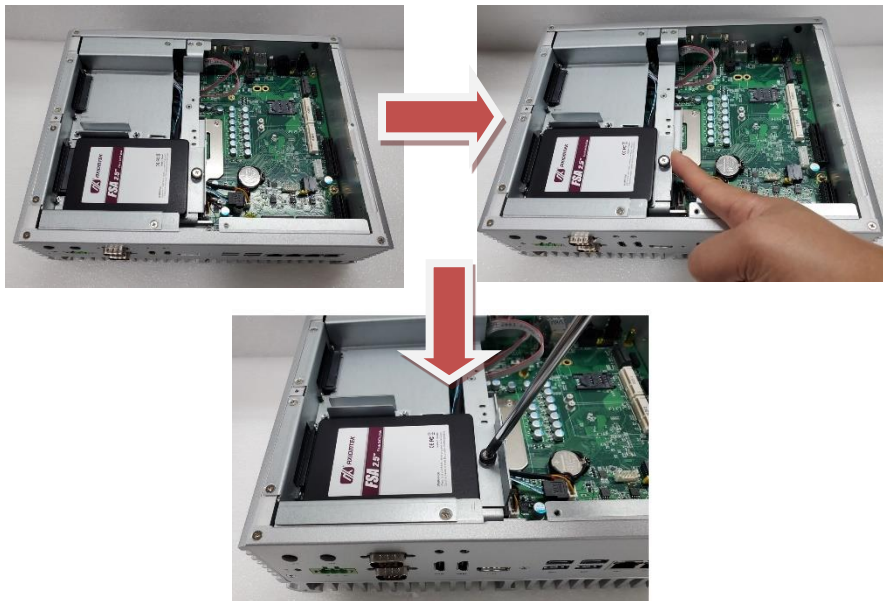

2.3 Installation of M.2 Mini PCIe Module (CN26)

Step 1 Turn off the system and unplug the power cord.

Step 2 Loosen three screws to remove bottom cover and locate M.2 mini card slot within the red line as marked.

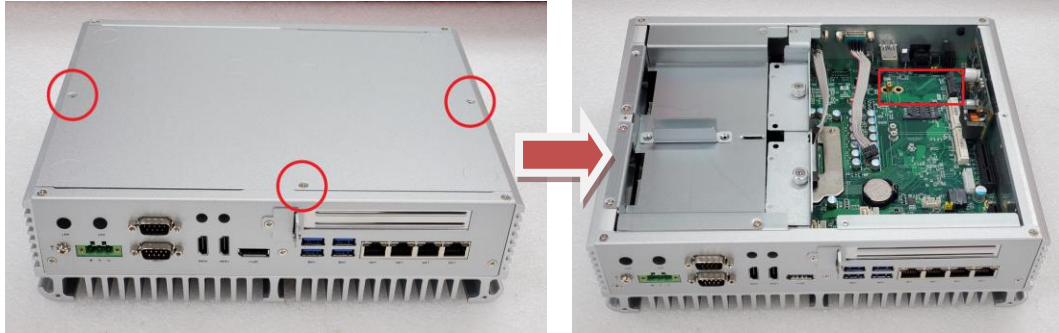

Step 3 Please use the M.2 bracket and thermal pad from accessory, attached the thermal pad on bracket as below red marked,

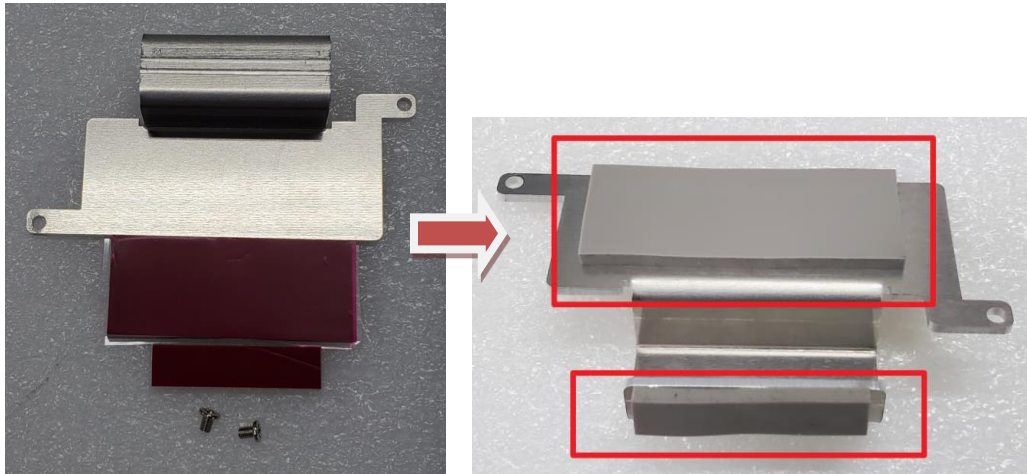

Step 4 Insert the M.2 mini card and fasten the two screws of the bracket. Make sure the direction is correct.



Step 5 Put the bottom cover and fasten all screws back onto the system.

2.4 Installation of Mini PCIe Module (Full-size)(CN17,CN20)

Step 1 Turn off the system and unplug the power cord.

Step 2 Loosen three screws to remove bottom cover and locate PCIe mini card slot within the red line as marked.

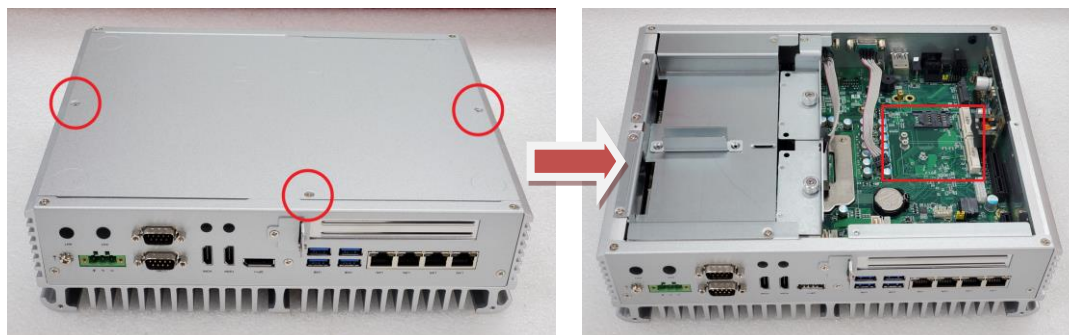

Step 3 Insert a mini PCIe module into the sockets and then fasten the screw.

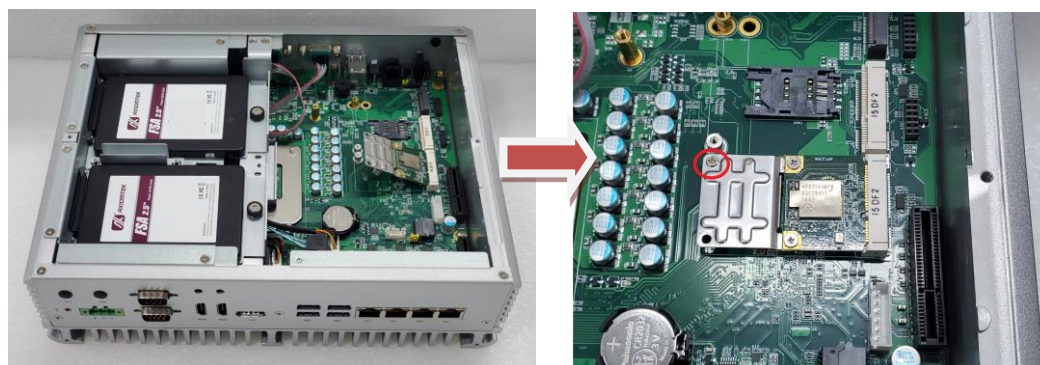

Step 4 Put the bottom cover and fasten all screws back onto the system.

SECTION 3 JUMPER & CONNECTOR SETTINGS

Proper jumper settings configure the eBOX710A to meet various application needs.-Hereby all jumpers settings along with their default settings are listed for devices onboard.

3.1 Locations of Jumpers & Connectors

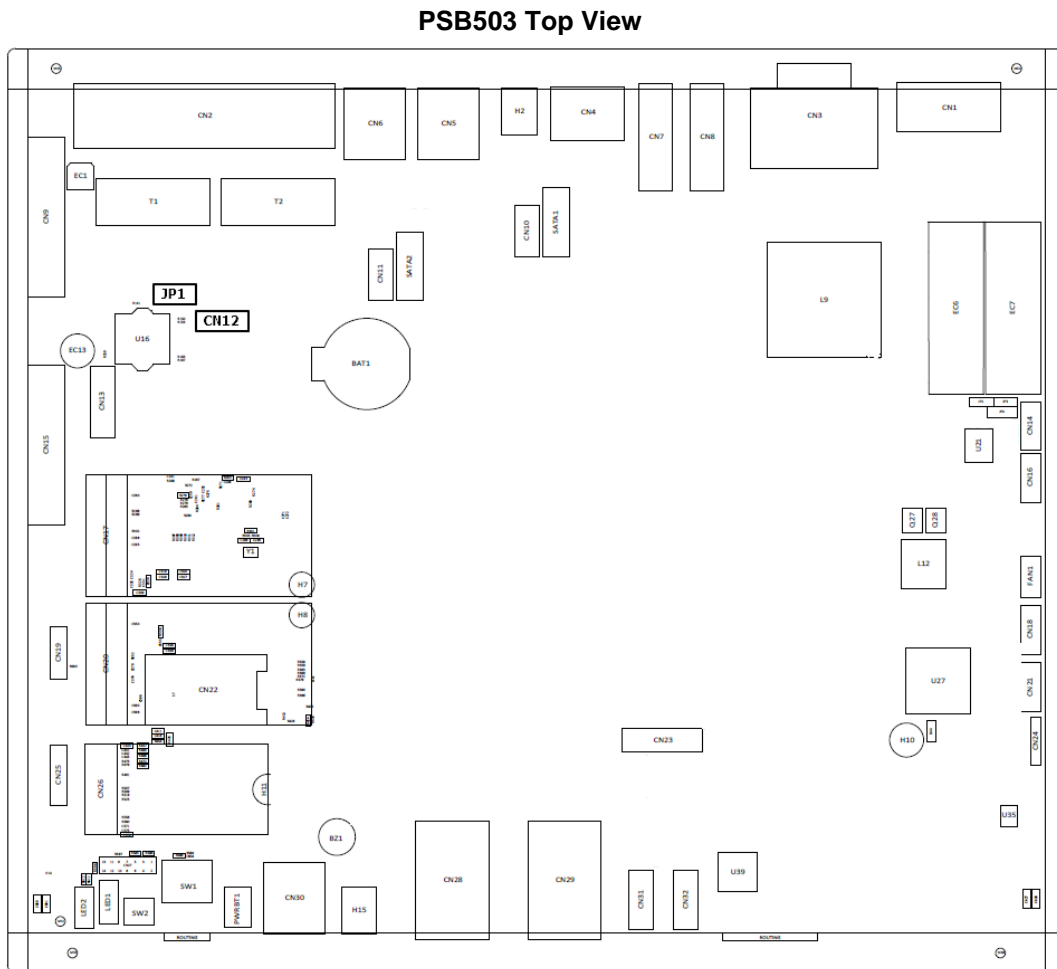

PSB503 Bottom View

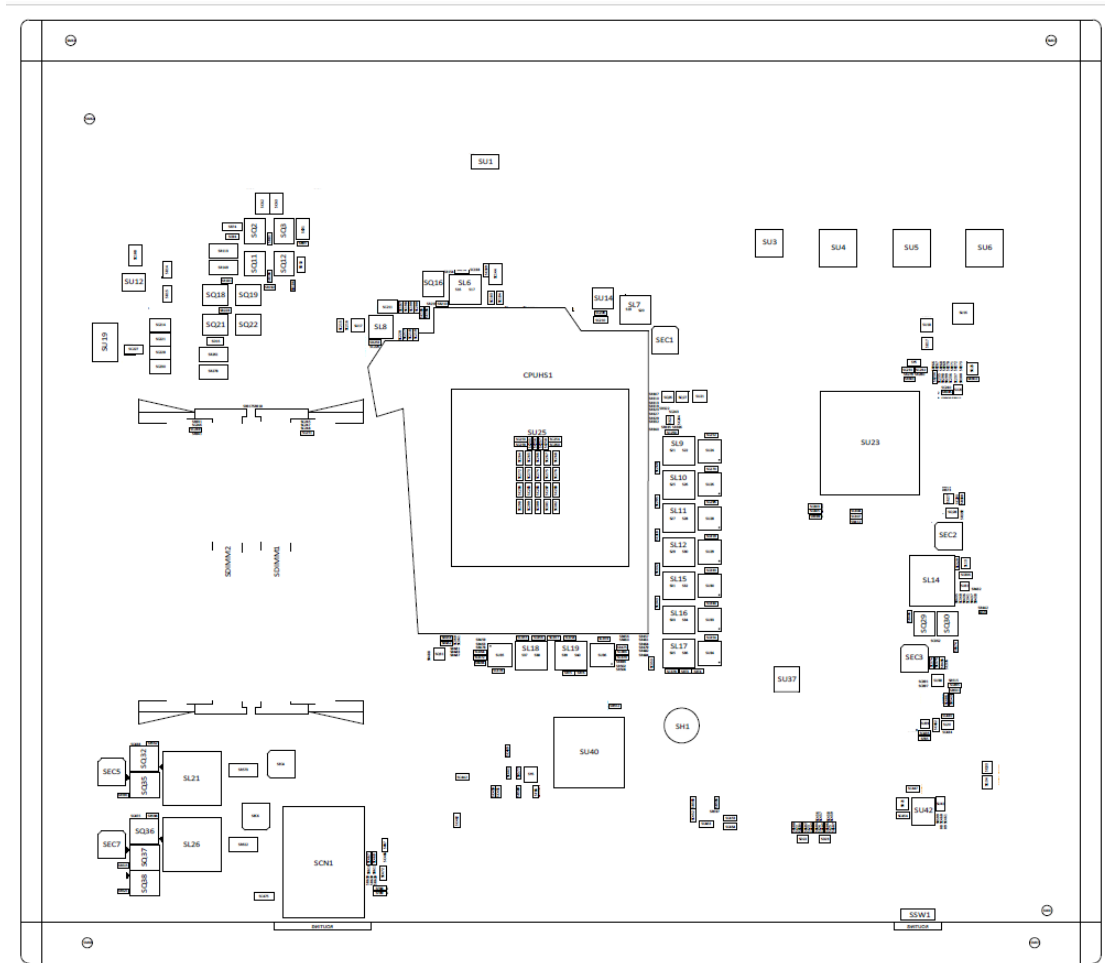

【Note】 : *It is strongly recommended that any unmentioned jumper settings should not be modified without instructions by Axiomtek FAEs. Any modifications without instructions might cause system failure.*

3.2 Summary of Jumper Settings

Proper jumper settings configure the eBOX710A to meet various application purposes. A table of all jumpers and their default settings is listed below.

Jumpers	Descriptions	Settings
JP1	Restore BIOS Optimal Defaults Default: Normal Operation	Short 1-2



【Note】 : How to setup Jumpers

That a cap on a jumper is to “close” the jumper, whereas that offs a jumper is to “open” the jumper.

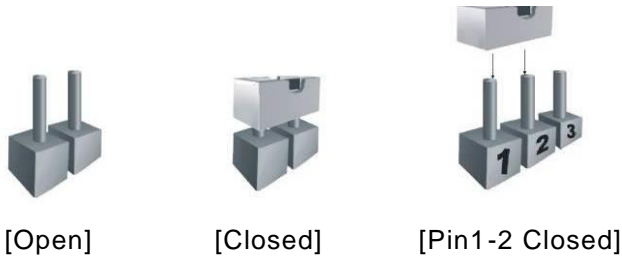

3.2.1 Restore BIOS Optimal Defaults (JP1)

Put jumper clip to pin 2-3 for a few seconds then move it back to pin 1-2. This procedure is to restore BIOS optimal defaults.

Functions	Settings
Normal (Default)	1-2
Clear RTC	2-3



3.3 Connectors

Please refer to below connector table to get their pin assignments.

External Connectors	Sections
DC-in Phoenix Power Connector	3.3.1
HDMI Connector	3.3.2
DisplayPort Connector	3.3.3
Serial Port Connector	3.3.4
USB 3.2 Connector	3.3.5
Ethernet Connector	3.3.6
ATX Power On/Off Button	3.3.7
Reset Button	3.3.8
Remote Power Switch Connector	3.3.9
AT/ATX Quick Switch	3.3.10
Internal Connectors	Sections
SATA Signal Connector	3.3.11
SATA Power Connector	3.3.12
SIM Slot	3.3.13
Full-Size Express Mini Card slot (CN17 & CN20)	3.3.14
M.2 Key B (CN26)	3.3.15
Optional Audio	3.3.16
Optional 8CH Digital IO (onboard)	3.3.17

3.3.1 DC-in Phoenix Power Connector (CN1)

The system supports 9~48V Phoenix DC-in connector for system power input.

Pins	Signals
1	DC+
2	GND
3	DC-

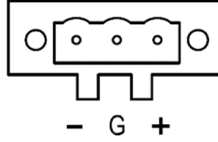

3.3.2 HDMI Connector (CN7, CN8)

The HDMI (High-Definition Multimedia Interface) is a compact digital interface which is capable of transmitting high-definition video and high-resolution audio over a single cable.

Pins	Signals	Pins	Signals
1	HDMI OUT_DATA2+	11	GND
2	GND	12	HDMI OUT Clock-
3	HDMI OUT_DATA2-	13	N.C.
4	HDMI OUT_DATA1+	14	N.C.
5	GND	15	HDMI OUT_SCL
6	HDMI OUT_DATA1-	16	HDMI OUT_SDA
7	HDMI OUT_DATA0+	17	GND
8	GND	18	+5V
9	HDMI OUT_DATA0-	19	HDMI_HTPLG
10	HDMI OUT Clock+		

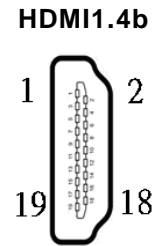

3.3.3 DisplayPort Connector (CN4)

eBOX710A supports one DisplayPort outputs.

Pins	Signals	Pins	Signals
1	DPB_LANE0	11	GND
2	GND	12	DPB_LANE3#
3	DPB_LANE0#	13	Detect Pin
4	DPB_LANE1	14	GND
5	GND	15	DPB_AUX
6	DPB_LANE1#	16	GND
7	DPB_LANE2	17	DPB_AUX#
8	GND	18	DPB_HPDE
9	DPB_LANE2#	19	GND
10	DPB_LANE3	20	+3.3V

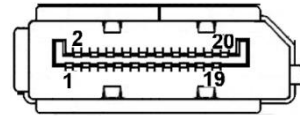

3.3.4 Serial Port Connector (CN3)(CN18)(CN21)

The system has two serial ports. COM1~COM2 are RS-232/422/485 ports. COM3~COM4 are RS-232 Please refer to Chapter 4 for the detail of BIOS setting.

Pins	RS-232	RS-422	RS-485
1	DCD, Data Carrier Detect	TX-	Data-
2	RXD, Receive Data	TX+	Data+
3	TXD, Transmit Data	RX+	No use
4	DTR, Data Terminal Ready	RX-	No use
5	GND, Ground	No use	No use
6	DSR, Data Set Ready	No use	No use
7	RTS, Request To Send	No use	No use
8	CTS, Clear To Send	No use	No use
9	RI, Ring Indicator	No use	No use

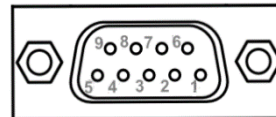

3.3.5 USB 3.2 Connector (CN5, CN6, CN30)

The system has six USB port, five port compliant with USB 3.2 gen1 (5GB/s), one port compliant with USB 2.0 (480MB/s), and ideally for installing USB peripherals such as scanner, camera, and USB devices, etc.

Pins	Signal USB Port 0	Pins	Signal USB Port 1
1	USB_VCC (+5V level standby power)	10	USB_VCC (+5V level standby power)
2	USB_Data-	11	USB_Data-
3	USB_Data+	12	USB_Data+
4	GND	13	GND
5	SSRX-	14	SSRX-
6	SSRX+	15	SSRX+
7	GND	16	GND
8	SSTX-	17	SSTX-
9	SSTX+	18	SSTX+

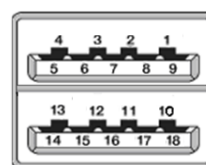

- ※ **CN5、CN30 are USB3.2 gen1**
- ※ **CN6 is one port USB3.2 gen1, one port USB 2.0**

3.3.6 Ethernet Connector (LAN1~LAN4)

The board has four RJ-45 Gbe ports connectors, LAN1 is designed by Intel i219LM and LAN2 to LAN4 are Intel i210-IT.

Pins	LAN Signal	Pins	LAN Signal
L1	MDI0+	L5	MDI2+
L2	MDI0-	L6	MDI2-
L3	MDI1+	L7	MDI3+
L4	MDI1-	L8	MDI3-
A	Activity link LED(Yellow) OFF: No link Blinking: Link established; data activity detected		
B	Speed LED OFF: 10Mbps data rate Green: 100Mbps data rate Orange: 1GMbps data rate		

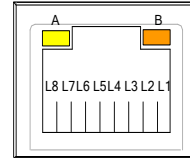

3.3.7 ATX Power On/Off (SW1)

The ATX power button is on the I/O side. It can allow users to control eBOX710A power on/off.

Functions	Descriptions
On	Turn on/off system
Off	Keep system status



3.3.8 ATX Power on/off (SW2)

The Reset button can allow users to reset eBOX710A system.

Functions	Descriptions
On	Reset system
Off	Keep system status



3.3.9 Remote Power Switch Connector (PWRBT1)

One 2-pin connector output for remote power on/off switch.

Functions	Descriptions
Short(1-2)	Turn on/off system
Open	Keep system status

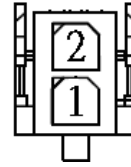

3.3.10 ATX/AT Quick Switch

If you set ATX /AT switch to AT mode, the system will be automatically power on without pressing soft power button during power input; we can use this switch to achieve auto power on demand.

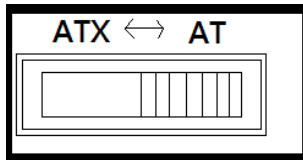

3.3.11 SATA Connector (SATA1 & 2)

These Serial Advanced Technology Attachment (Serial ATA or SATA) connectors are for high-speed SATA interfaces. They are computer bus interfaces for connecting to devices such as hard disk drives. This board has two SATA 3.0 ports with 6Gb/s performance.

Pins	Signals
1	GND
2	SATA_TX+
3	SATA_TX-
4	GND
5	SATA_RX-
6	SATA_RX+
7	GND

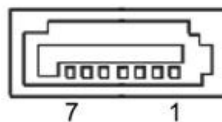

3.3.12 SATA Power Connector (CN10,CN11)

Based on CN10、CN11 to offer the SATA power for SATA 2.5" HDD/SSD.

Pins	Signals
1	+12V level
2	GND
3	GND
4	+5V level

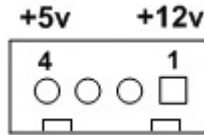

3.3.13 SIM Card Slots (SCN1, CN22)

The eBOX710A includes two SIM slots: SCN1 on top side of the system that support M.2 Key B (for CN26), CN22 on bottom side that support mini PCIe slot (for CN20). It is mainly used in wireless network application on CN20 and CN26.

Pins	Signals
1	PWR
2	RST
3	CLK
4	NC
5	GND
6	VPP
7	I/O
8	NC

SCN1

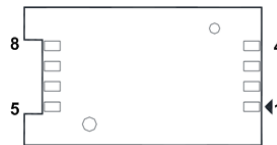

CN22

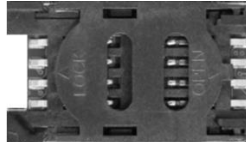

3.3.14 Full-Size PCI Express Mini Card Slot (CN17,CN20)

The eBOX710A supports dual full-size PCI-Express Mini Card slots.

CN17 and CN20 is applying for PCI-Express or SATA (mSATA) via BIOS selection and USB signals; PCI-Express complies with PCI-Express Mini Card Spec. V1.2. Thus, users can install mSATA or WLAN/WWAN cards into this slot. Please refer to the SATA of BIOS setting to enable or disable mSATA supported.

※ **CN20 support SIM slot.**

CN17

Pins	Signals	Pins	Signals
1	WAKE#	2	+3.3VSB
3	No use	4	GND
5	No use	6	+1.5V
7	CLKREQ#	8	No use
9	GND	10	No use
11	REFCLK-	12	No use
13	REFCLK+	14	No use
15	GND	16	No use
17	No use	18	GND
19	No use	20	W_DISABLE#
21	GND	22	PERST#
23	PE_RXN3/	24	+3.3VSB
25	PE_RXP3/	26	GND
27	GND	28	+1.5V
29	GND	30	SMB_CLK
31	PE_TXN3/	32	SMB_DATA
33	PE_TXP3/	34	GND
35	GND	36	USB_D8-
37	GND	38	USB_D8+
39	+3.3VSB	40	GND
41	+3.3VSB	42	No use
43	GND	44	No use
45	No use	46	No use
47	No use	48	+1.5V
49	No use	50	GND
51	No use	52	+3.3VSB

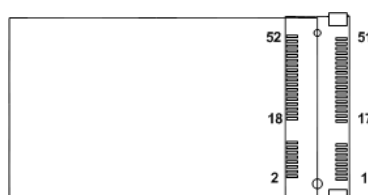

CN20

Pins	Signals	Pin	Signals
1	WAKE#	2	+3.3VSB
3	No use	4	GND
5	No use	6	+1.5V
7	CLKREQ#	8	SIM_PWR
9	GND	10	SIM_DATA
11	REFCLK-	12	SIM_CLK
13	REFCLK+	14	SIM_RESET
15	GND	16	SIM_VPP
17	No use	18	GND
19	No use	20	W_DISABLE#
21	GND	22	PERST#
23	PE_RXN3/mSATA	24	+3.3VSB
25	PE_RXP3/mSATA	26	GND
27	GND	28	+1.5V
29	GND	30	SMB_CLK
31	PE_TXN3/ mSATA	32	SMB_DATA
33	PE_TXP3/ mSATA	34	GND
35	GND	36	USB_D8-
37	GND	38	USB_D8+
39	+3.3VSB	40	GND
41	+3.3VSB	42	No use
43	GND	44	No use
45	No use	46	No use
47	No use	48	+1.5V
49	No use	50	GND
51	No use	52	+3.3VSB

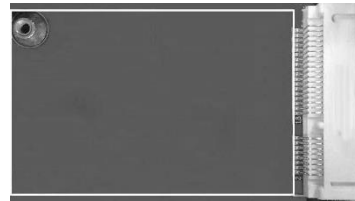
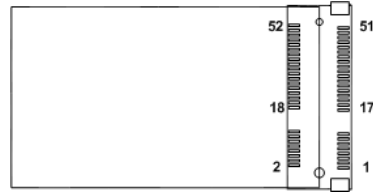

3.3.15 M.2 3050/3052 Key B slot (CN26)

The M.2 3050/3052 Key B for 5G Module.

Pins	Signals	Pins	Signals	Pins	Signals	Pins	Signals
1	NC	2	+3.3V	3	GND	4	+3.3V
5	GND	6	NC	7	USB_D+	8	NC
9	USB_D-	10	NC	11	GND	12	Key B
13	Key B	14	Key B	15	Key B	16	Key B
17	Key B	18	Key B	19	Key B	20	NC
21	NC	22	NC	23	NC	24	NC
25	NC	26	NC	27	GND	28	NC
29	USB3.1-Tx-	30	UIM-RESET	31	USB3.1-Tx+	32	UIM-CLK (O)
33	GND	34	UIM-DATA (I/O)	35	USB3.1-Rx-	36	UIM-PWR (O)
37	USB3.1-Rx+	38	NC	39	GND	40	NC
41	NC	42	NC	43	NC	44	NC
45	GND	46	NC	47	NC	48	NC
49	NC	50	PERST#	51	GND	52	NC
53	NC	54	PEWAKE#	55	NC	56	NC
57	GND	58	NC	59	NC	60	NC
61	NC	62	NC	63	NC	64	NC
65	NC	66	NC	67	RESET# (I)(0/1.8V)	68	NC
69	NC	70	+3.3V	71	GND	72	+3.3V
73	GND	74	+3.3V	75	NC		

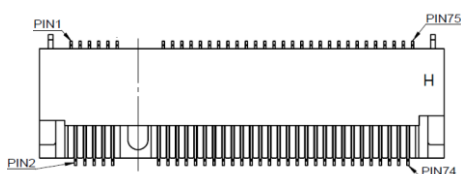

3.3.16 Intel® HD Audio Digital Header (CN31, CN32)(Optional)

These two audio jacks are ideal for Audio Mic-In and Audio Line-out.

Pin	Signal
1	Line Out
2	Microphone In

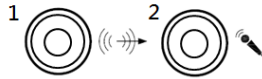

3.3.17 Digital I/O (CN14 and CN16) (optional)

The system is equipped with 16bit programmable Digital I/O, please refer to the following table to get default pin define. Default is 8in/8out.

The digital I/O can be configured to control cash drawers and sense warning signals from an Uninterrupted Power System (UPS) or perform store security control. You may use software programming to control these digital signals.

CN14

Pins	Signals	Pins	Signals
1	DIO1_IN	2	DIO8_OUT
3	DIO2_IN	4	DIO7_OUT
5	DIO3_IN	6	DIO6_OUT
7	DIO4_IN	8	DIO5_OUT
9	+5V	10	GND

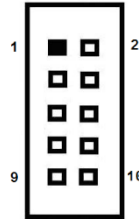

CN16

Pins	Signals	Pins	Signals
1	DIO9_IN	2	DIO16_OUT
3	DIO10_IN	4	DIO15_OUT
5	DIO11_IN	6	DIO14_OUT
7	DIO12_IN	8	DIO13_OUT
9	+5V	10	GND

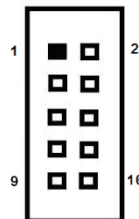

SECTION 4 BIOS SETUP UTILITY

This section provides users with detailed descriptions in terms of how to set up basic system configurations through the BIOS setup utility.

4.1 Starting

To enter the setup screens, follow the steps below:

1. Turn on the computer and press the key immediately.
2. After press the key, the main BIOS setup menu displays. Users can access to other setup screens, such as the Advanced and Chipset menus, from the main BIOS setup menu.

It is strongly recommended that users should avoid changing the chipset's defaults. Both AMI and system manufacturer have carefully set up these defaults that provide the best performance and reliability.

4.2 Navigation Keys

The BIOS setup/utility uses a key-based navigation system called hot keys. Most of the BIOS setup utility hot keys can be used at any time during the setup navigation process. These keys include <F1>, <F2>, <Enter>, <ESC>, <Arrow> keys, and so on.



【Note】 : Some of the navigation keys differ from one screen to another.

Hot Keys	Descriptions
→← Left/Right	The Left and Right <Arrow> keys allow users to select a setup screen.
↑↓ Up/Down	The Up and Down <Arrow> keys allow users to select a setup screen or sub-screen.
+– Plus/Minus	The Plus and Minus <Arrow> keys allow users to change the field value of a particular setup item.
Tab	The <Tab> key allows users to select setup fields.
F1	The <F1> key allows users to display the General Help screen.
F2	The <F2> key allows users to Load Previous Values.
F3	The <F3> key allows users to Load Optimized Defaults.
F4	The <F4> key allows users to save any changes they made and exit the Setup. Press the <F4> key to save any changes.
Esc	The <Esc> key allows users to discard any changes they made and exit the Setup. Press the <Esc> key to exit the setup without saving any changes.
Enter	The <Enter> key allows users to display or change the setup option listed for a particular setup item. The <Enter> key can also allow users to display the setup sub- screens.

4.3 Main Menu

The Main Menu screen is the first screen users see when entering the setup utility. Users can always return to the Main setup screen by selecting the Main tab. System Time/Date can be set up as described below. The Main BIOS setup screen is also shown below.

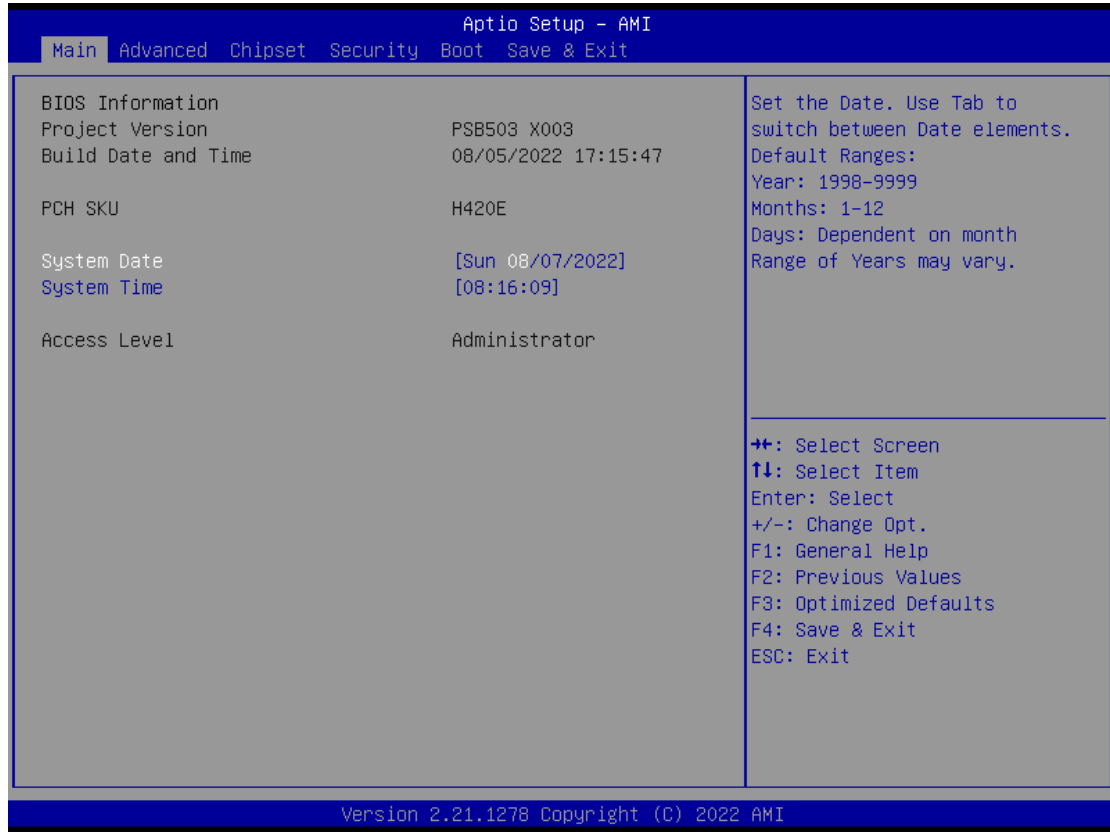

BIOS Information

Display the auto-detected BIOS information.

System Date/Time

Use this option to change the system time and date. Highlight System Time or System Date using the <Arrow> keys. Enter new values through the keyboard. Press the <Tab> key or the <Arrow> keys to move between fields. The date must be entered in MM/DD/YY format. The time is entered in HH:MM:SS format.

Access Level

Display the access level of current user.

4.4 Advanced Menu

The Advanced menu also allows users to set configuration of the CPU and other system devices. Users can select any items in the left frame of the screen to go to sub menus:

- ▶ PCIE/SATA Switch1
- ▶ PCIE/SATA Switch2
- ▶ LED1-4
- ▶ ACPI Settings
- ▶ Trusted Computing
- ▶ CPU Configurations
- ▶ SATA & RST Configuration
- ▶ NCT6116D Super IO Configuration
- ▶ NCT6116D Hardware Monitor
- ▶ PCH-FW Configuration
- ▶ USB Configuration
- ▶ Device Configuration

For items marked with “▶”, please press <Enter> for more options.

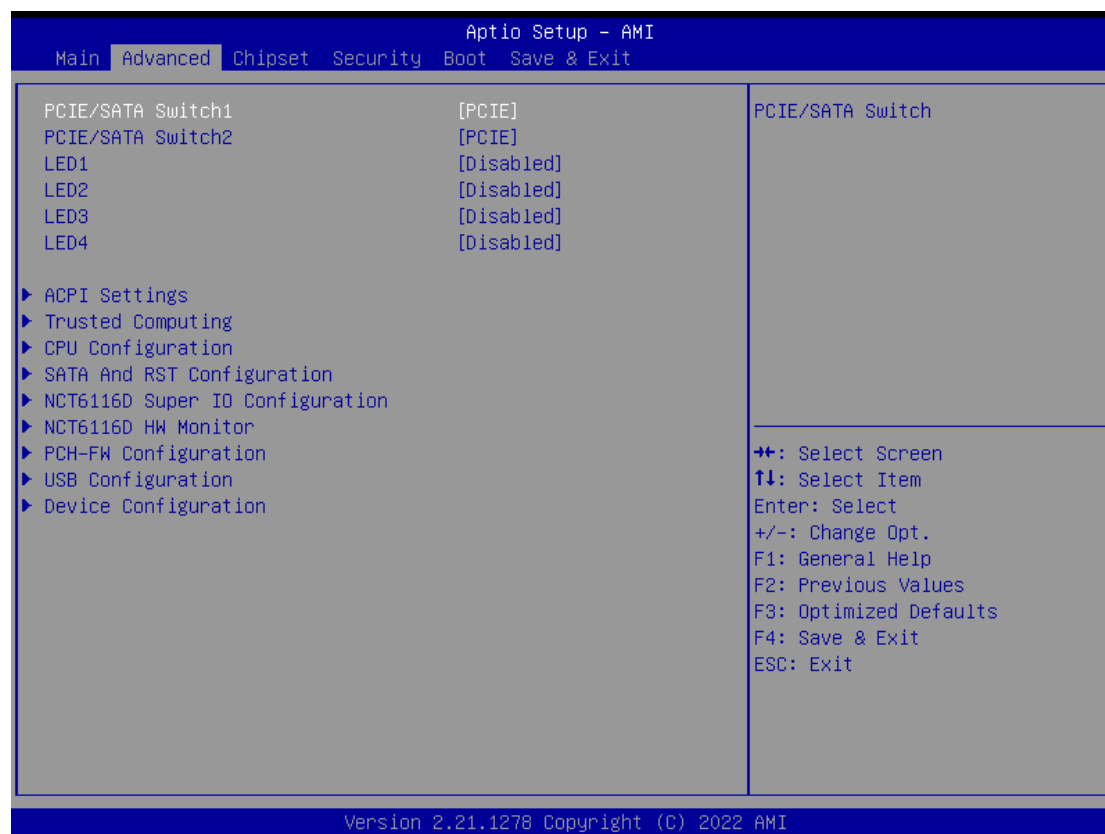

PCIE/SATA Switch1/PCIE/SATA Switch2

Use this to select Mini Card setting, default is “PCIE”.

*PCIE/SATA Switch1: CN17, PCIE//SATA Switch 2: CN20

LED1-4

Use this to enable or disable programmable LED

ACPI Settings

Use this screen to select options for the ACPI configuration and change the value of the selected option. A description of the selected item appears on the right side of the screen.

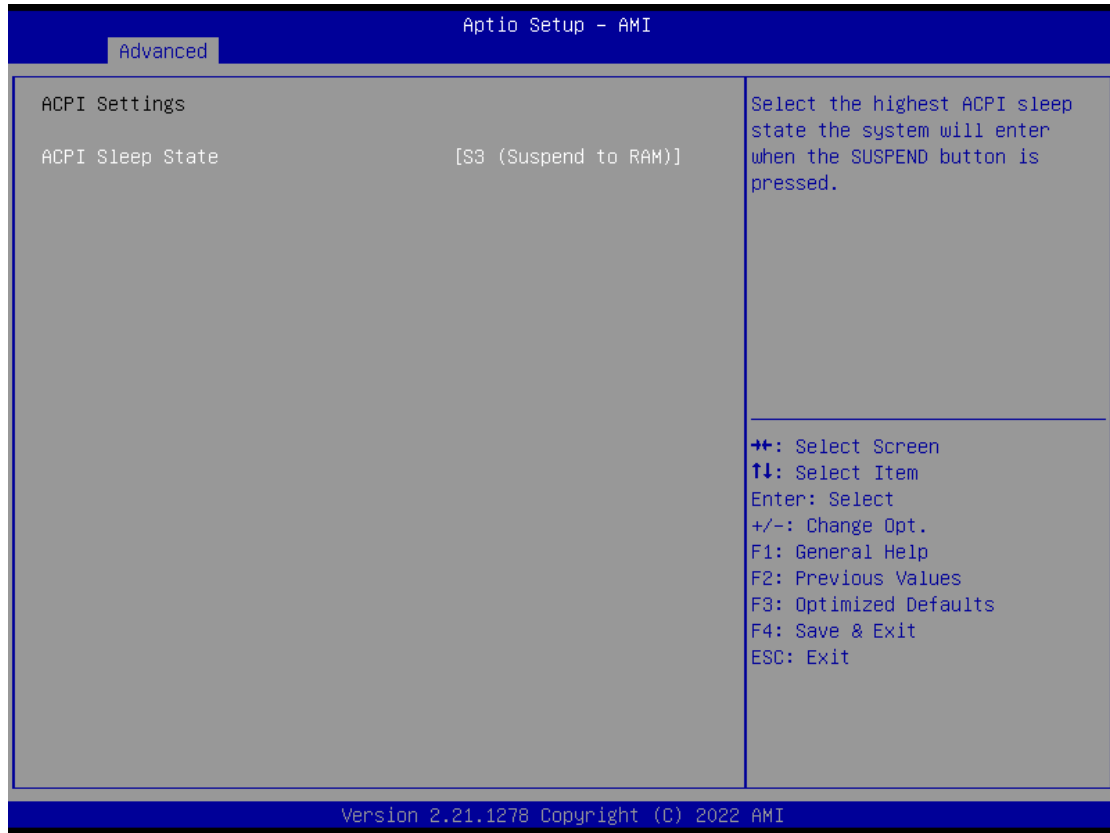

ACPI Sleep State

When the sleep button is pressed, the system will be in the ACPI sleep state.

The default is S3 (Suspend to RAM).

Trust Computing

If users install a security device, such as TPM, users will see the following information for the TPM device and status.

Advanced		Aptio Setup - AMI	
TPM 2.0 Device Found			Enables or Disables BIOS support for security device. O.S. will not show Security Device. TCG EFI protocol and INT1A interface will not be available.
Firmware Version:	71.4		
Vendor:	STM		
Security Device Support	[Enable]		
			++: Select Screen ↑↓: Select Item Enter: Select +/-: Change Opt. F1: General Help F2: Previous Values F3: Optimized Defaults F4: Save & Exit ESC: Exit
Version 2.21.1278 Copyright (C) 2022 AMI			

CPU Configuration

This screen shows the CPU version and its detailed information.

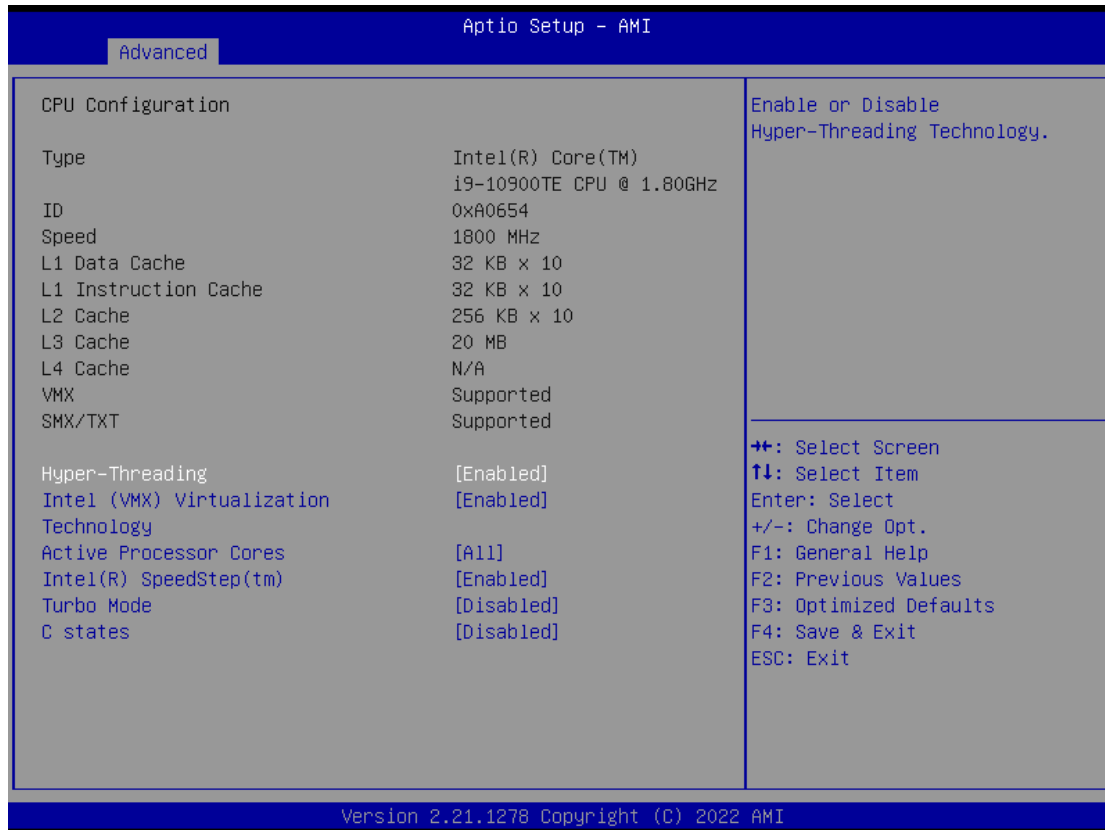

Hyper-Threading

It allows a hardware platform to run multiple operating systems separately and simultaneously, enabling one system to virtually function as several systems.

Intel Virtualization Technology

Enable or disable Intel Virtualization Technology. When enabled, a VMM (Virtual Machine Mode) can utilize the additional hardware capabilities. It allows a platform to run multiple operating systems and applications independently, hence enabling a single computer system to work as several virtual systems.

Active Processor Cores

Number of cores to enable in each processor package.

Intel (R) SpeedStep(tm)

Allows more than two frequency ranges to be supported.

Turbo Mode

Enable/Disable processor Turbo Mode (requires EMTTM enabled too). AUTO means enabled, unless max turbo ratio is bigger than 16 - SKL A0 W/A.

C states

Enable/Disable CPU Power Management, which allows CPU to go to power saving Cstates when it's not 100% utilized.

SATA & RST Configuration

In this Configuration menu, you can see the currently installed hardware in the SATA ports. During system boot up, the BIOS automatically detects the presence of SATA devices.

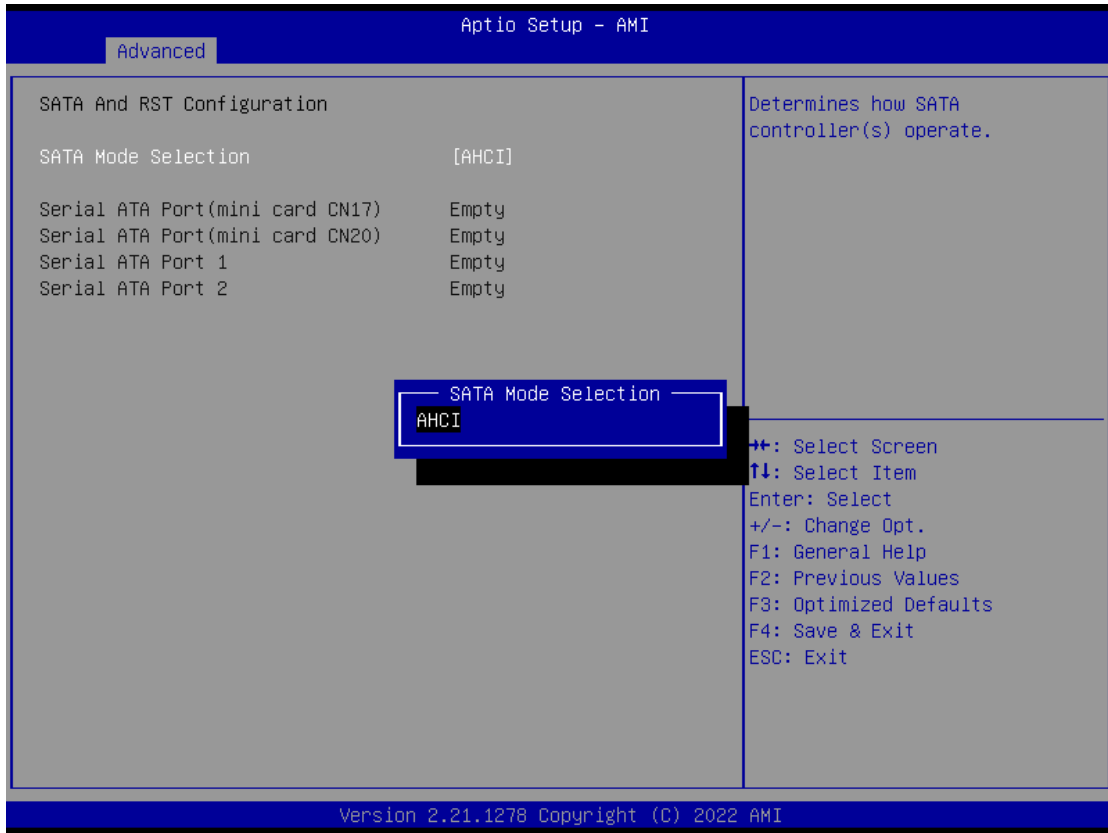

SATA Mode Selection

AHCI (Advanced Host Controller Interface) mode is how SATA controller(s) operate.

Serial ATA Port 1~4

It shows the device installed in connector SATA1~4.

NCT6116D Super IO Configurations

Use this screen to select options for the NCT6116D Super IO Configurations and change the value of the selected option. A description of the selected item appears on the right side of the screen. For items marked with “▶”, please press <Enter> for more options

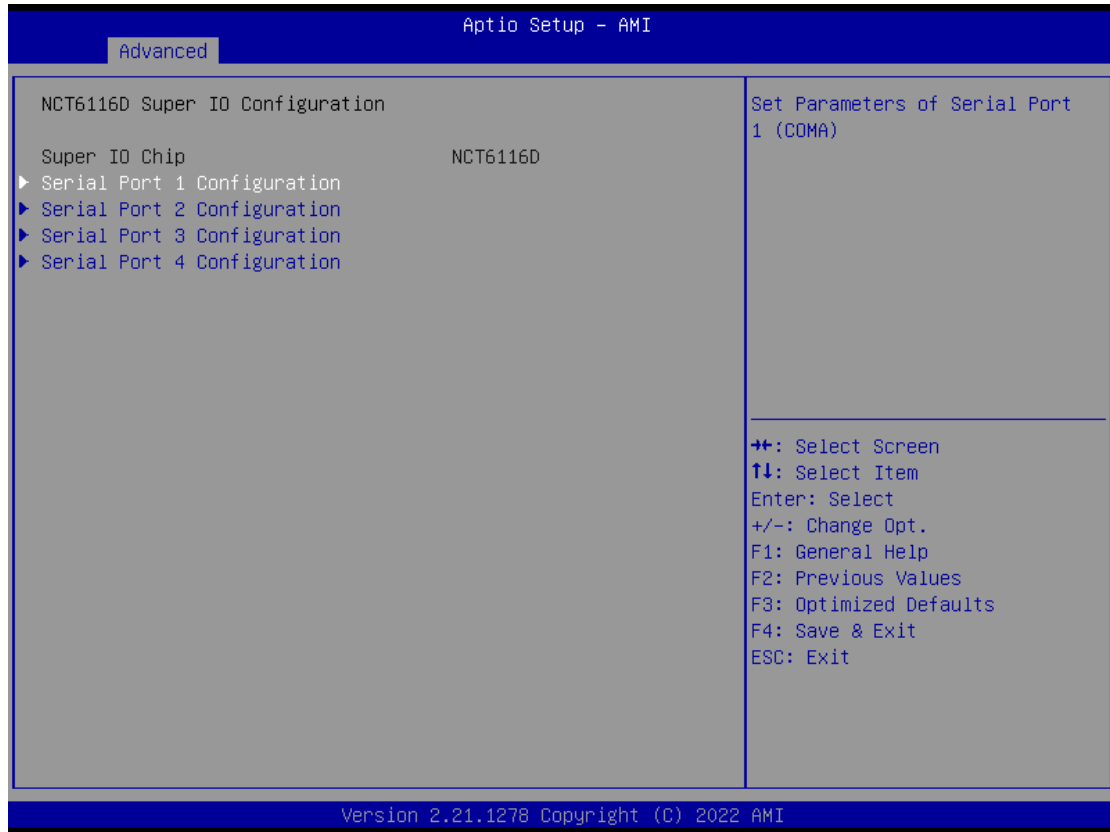

Serial Port 1~4 (COM1~4) Configurations

Use these items to set parameters related to serial ports COM1~2 (RS232/422/485)

Use these items to set parameters related to serial ports COM3~4 (RS232 only)

Serial Port 1

Use this to set parameters of COM 1.

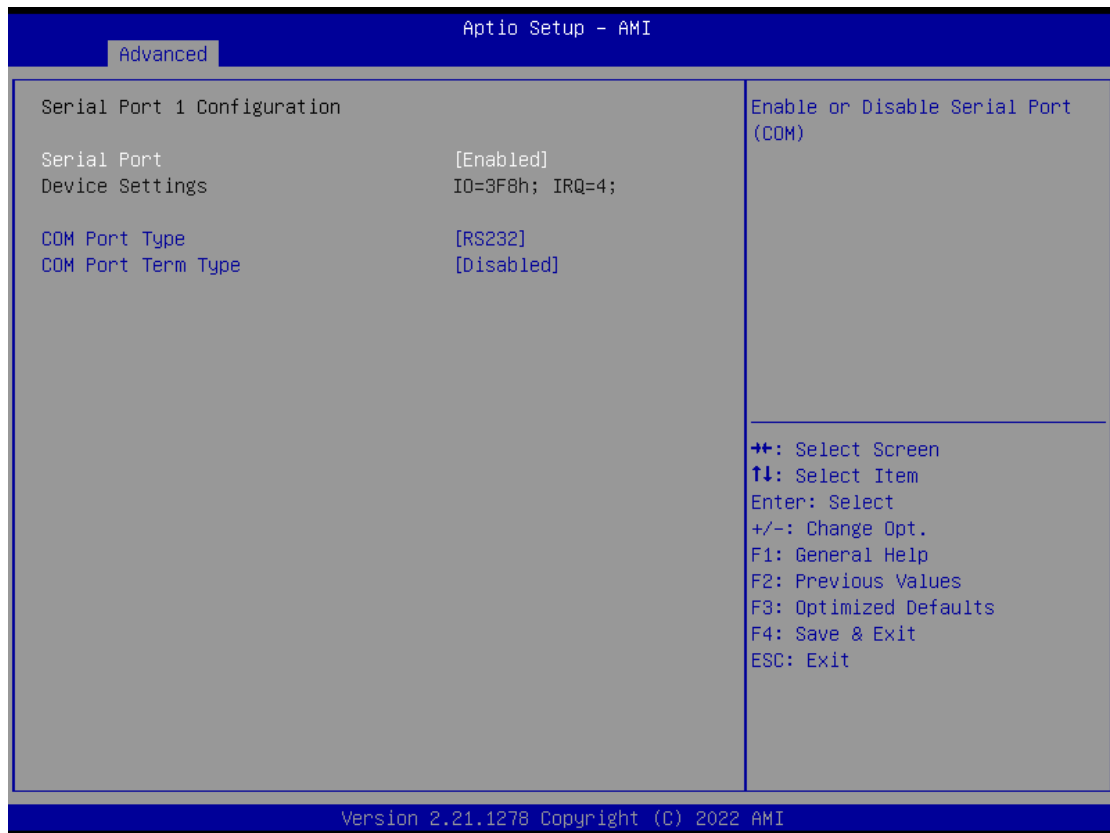

COM Port type

Use this item to set parameters related to serial ports COM1 (RS232/422/485)

COM Port term type

Use this item to select COM port terminal type.

Serial Port 2

Use this to set parameters of COM 2.



COM Port type

Use this item to set parameters related to serial ports COM 2 (RS232/422/485)

COM Port term type

Use this item to select COM port terminal type.

Serial Port 3

Aptio Setup - AMI	
Advanced	
Serial Port 3 Configuration	Enable or Disable Serial Port (COM)
Serial Port [Enabled]	
Device Settings IO=3E8h; IRQ=5;	
	++: Select Screen ↑↓: Select Item Enter: Select +/-: Change Opt. F1: General Help F2: Previous Values F3: Optimized Defaults F4: Save & Exit ESC: Exit
Version 2.21.1278 Copyright (C) 2022 AMI	

Serial Port 4

Aptio Setup - AMI	
Advanced	
Serial Port 4 Configuration	Enable or Disable Serial Port (COM)
Serial Port [Enabled]	
Device Settings IO=2E8h; IRQ=10;	
	++: Select Screen ↑↓: Select Item Enter: Select +/-: Change Opt. F1: General Help F2: Previous Values F3: Optimized Defaults F4: Save & Exit ESC: Exit
Version 2.21.1278 Copyright (C) 2022 AMI	

NCT6116D Hardware Monitor

This screen monitors hardware health status.

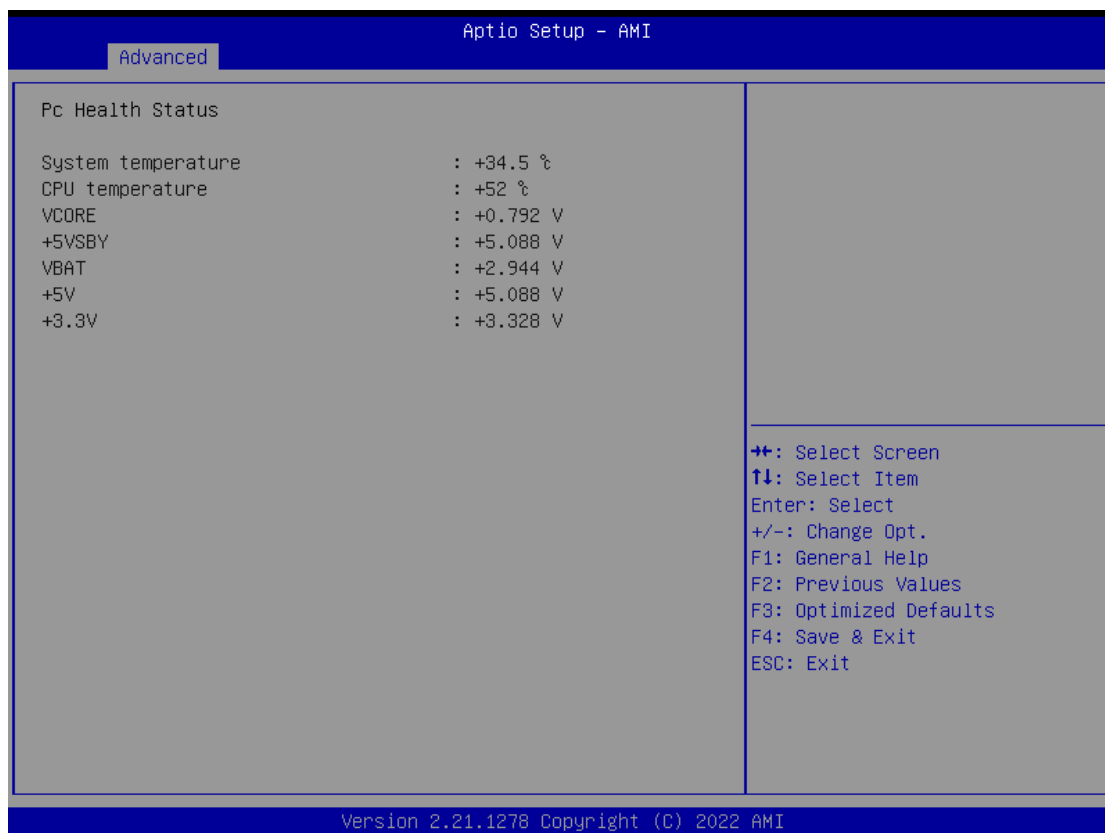

This screen displays the temperature of system and CPU as well as system voltages (V CORE, +3.3V, +5V STBY and +5V).

PCH-FW Configuration

This screen shows ME Firmware information.

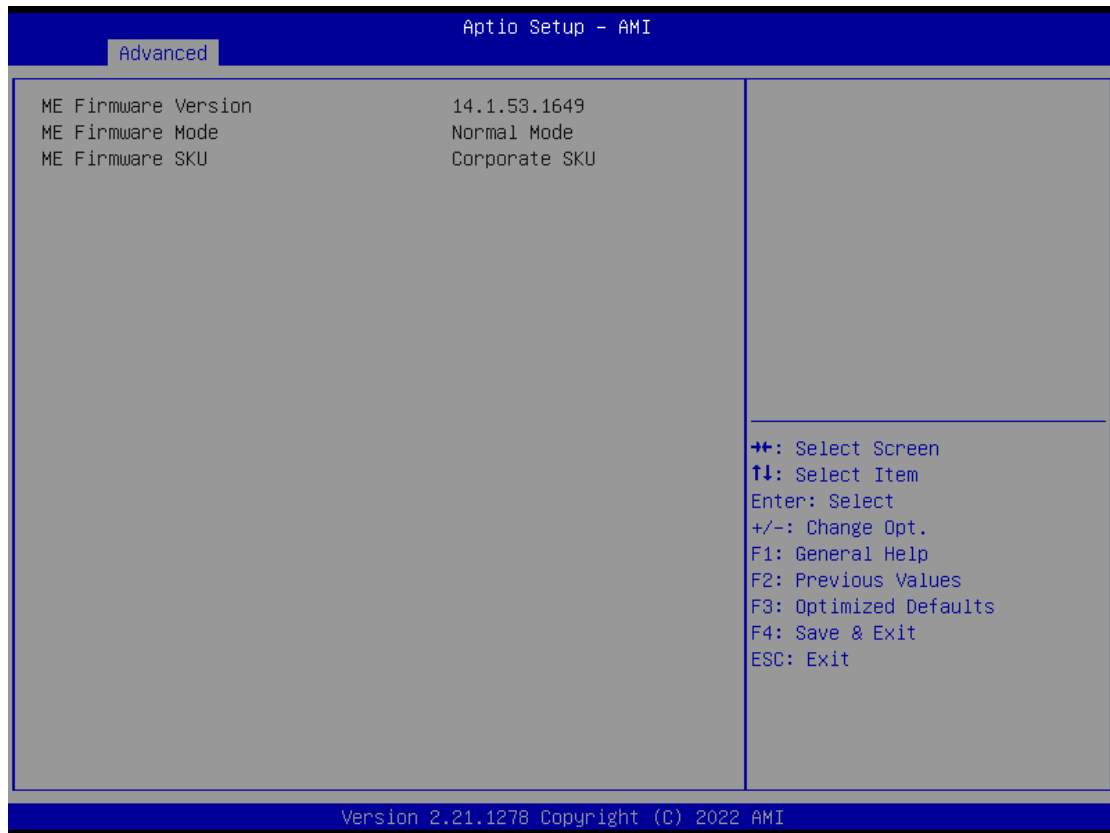

USB Configurations

Users can use this screen to configure USB configurations. (換圖，拿掉 mass storage device)

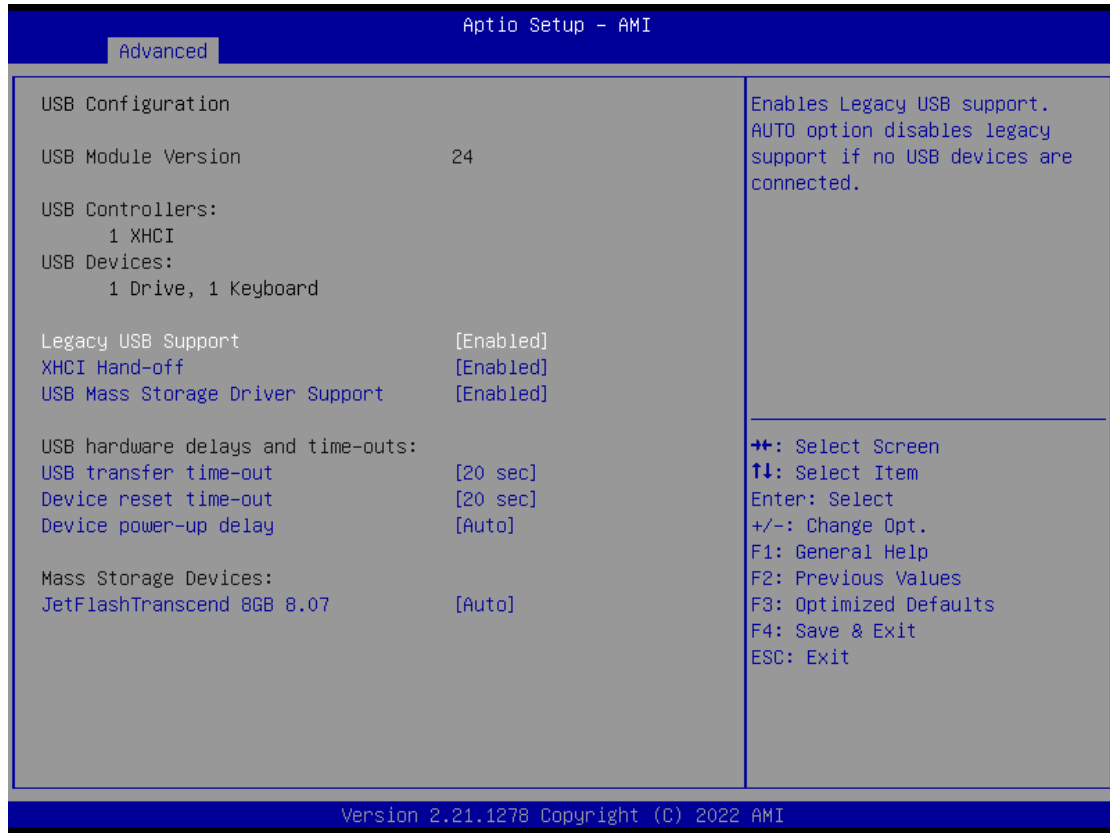

Legacy USB Support

Enables Legacy USB support. AUTO option disables legacy support if no USB devices are connected.

XHCI Hand-off

This is a workaround for Oses without XHCI hand-off support. The XHCI ownership change should be claimed by XHCI driver.

USB Mass Storage Driver Support

Enable/Disable USB Mass Storage Driver Support.

USB transfer time-out

The time-out value for Control, Bulk, and Interrupt transfers.

Device reset time-out

USB mass storage device Start Unit command time-out.

Device power-up delay

Maximum time the device will take before it properly reports itself to the Host Controller. 'Auto' uses default value: for a Root port it is 100 ms, for a Hub port the delay is taken from Hub descriptor.

Device Configurations

Users can use this screen to configure Device configurations.

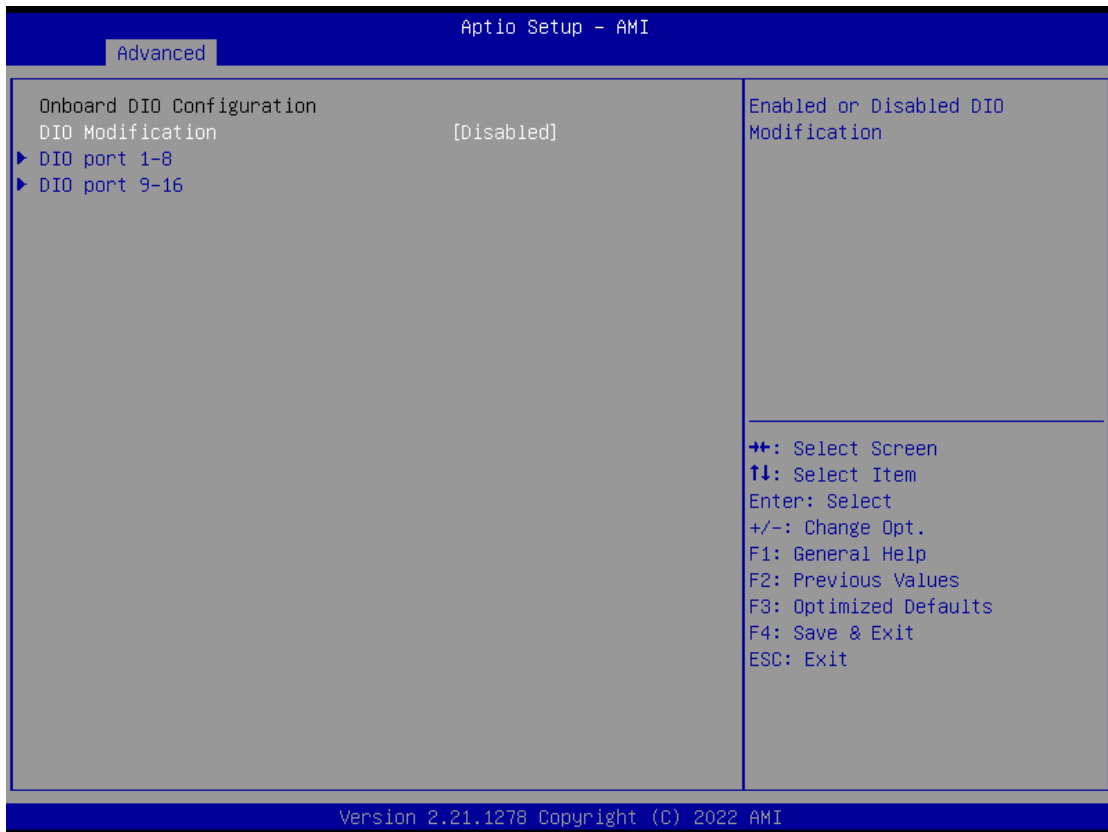

Aptio Setup - AMI

Advanced

DIO status	
1. Input/Output Status	In & High
2. Input/Output Status	In & High
3. Input/Output Status	In & High
4. Input/Output Status	In & High
5. Input/Output Status	Out & High
6. Input/Output Status	Out & High
7. Input/Output Status	Out & High
8. Input/Output Status	Out & High

++: Select Screen
↑↓: Select Item
Enter: Select
+/-: Change Opt.
F1: General Help
F2: Previous Values
F3: Optimized Defaults
F4: Save & Exit
ESC: Exit

Version 2.21.1278 Copyright (C) 2022 AMI

4.5 Chipset Menu

The Chipset menu allows users to change the advanced chipset settings. Users can select any of the items in the left frame of the screen to go to the sub menus:

- ▶ System Agent (SA) Configurations
- ▶ PCH-IO Configurations

For items marked with “▶”, please press <Enter> for more options.



System Agent (SA) Configurations

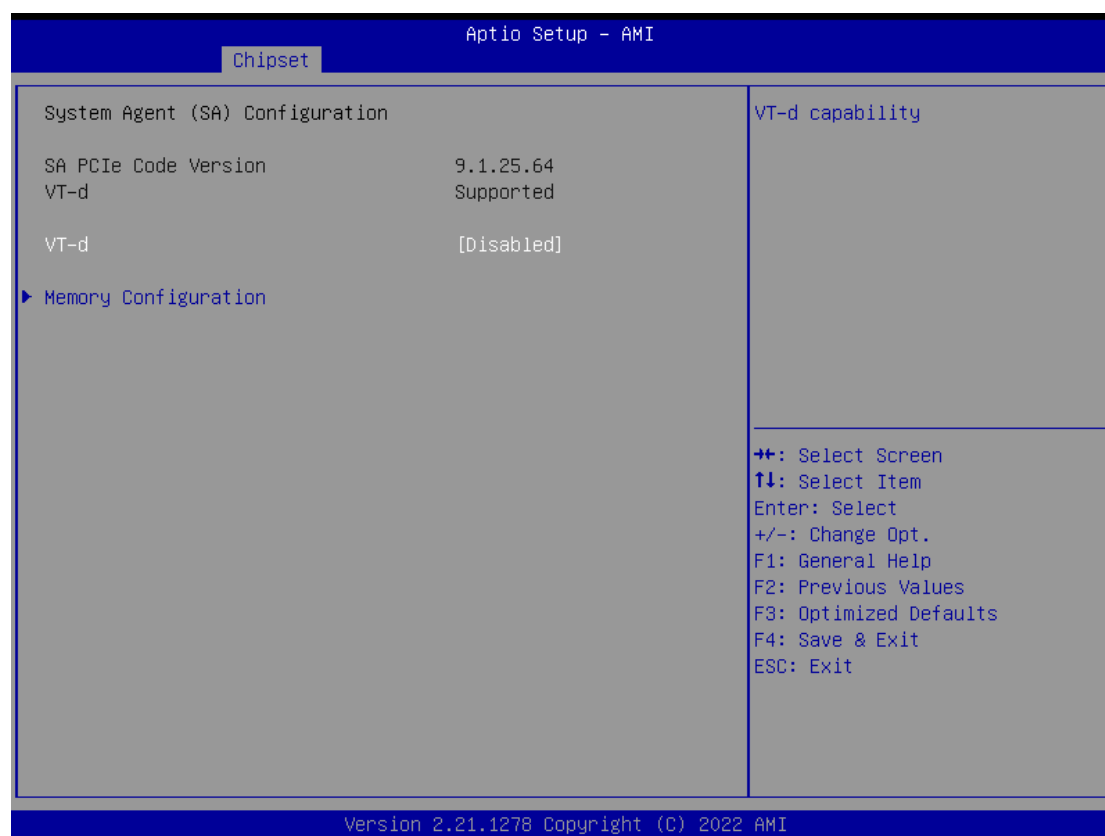

VT-d

VT-d capability.

Memory Configuration

Use this item to refer to the information related to system memory.

Memory Configurations

This screen shows the system memory information.

The screenshot displays the 'Chipset' section of the Aptio Setup - AMI BIOS utility. The main area shows memory configuration details, and a legend on the right explains the navigation keys.

Chipset	
Memory RC Version	0.0.0.67
Total Memory	4096 MB
DIMM#1	Not Populated / Disabled
DIMM#3	Populated & Enabled
Size	4096 MB (DDR4)

⇧⇧: Select Screen
⇧↓: Select Item
Enter: Select
+/-: Change Opt.
F1: General Help
F2: Previous Values
F3: Optimized Defaults
F4: Save & Exit
ESC: Exit

Version 2.21.1278 Copyright (C) 2022 AMI

PCH-IO Configurations

This screen allows users to set PCH parameters.



PCH LAN Controller

Enable or disable onboard PCH LAN controller.

Wake on LAN Enable

Enable or disable integrated LAN to wake the system.

HD Audio Configuration

Enable or disable HD Audio.

Security Menu

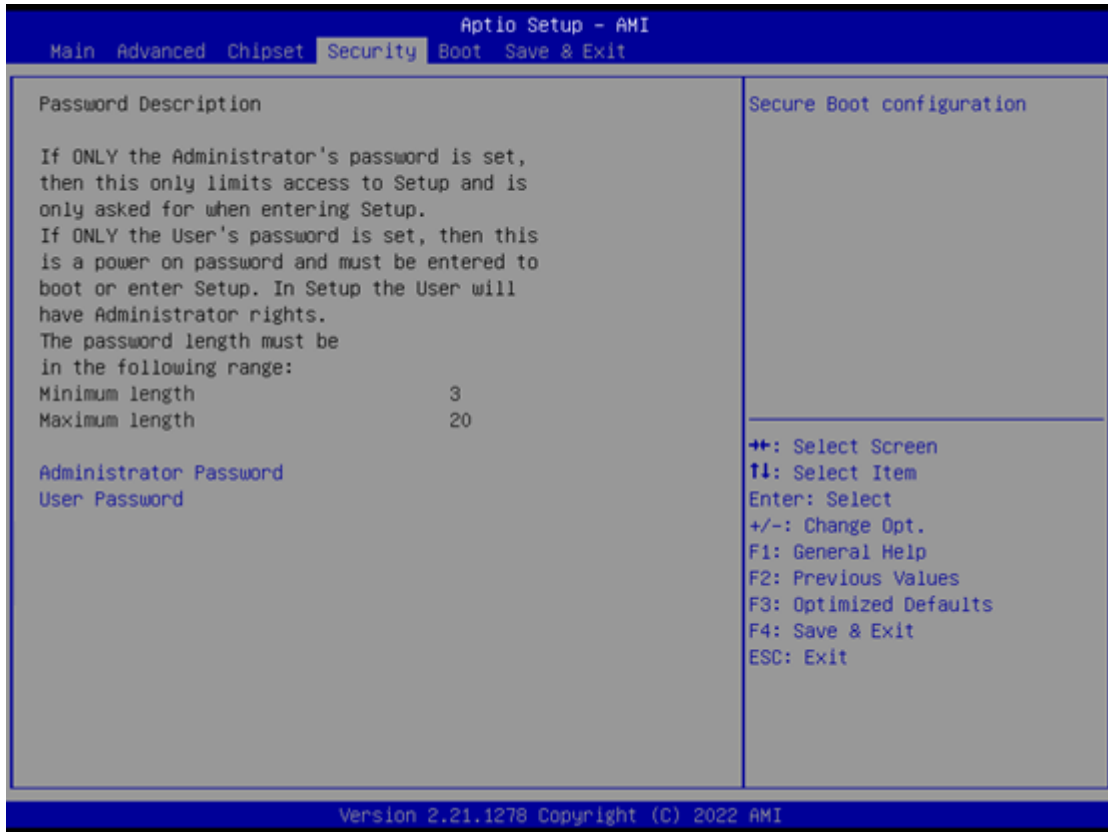

Administrator Password

This item indicates whether an administrator password has been set (installed or uninstalled).

User Password

This item indicates whether a user password has been set (installed or uninstalled).

4.6 Boot Menu

The Boot menu allows users to change boot options of the system.



Setup Prompt Timeout

Use this item to set up number of seconds to wait for setup activation key where 65535(0xFFFF) means indefinite waiting.

Bootup NumLock State

Use this item to select the power-on state for the keyboard NumLock.

Quiet Boot

Select to display either POST output messages or a splash screen during boot-up.

Launch PXE OpROM policy

Enables UEFI to run those devices that support UEFI option ROM only. Selecting Legacy enables only devices that support legacy option ROM only.

Boot Option Priorities

These are settings for boot priority. Specify the boot device priority sequence from the available devices.

4.7 Save & Exit Menu

The Save & Exit menu allows users to load system configurations with optimal or fail-safe default values.

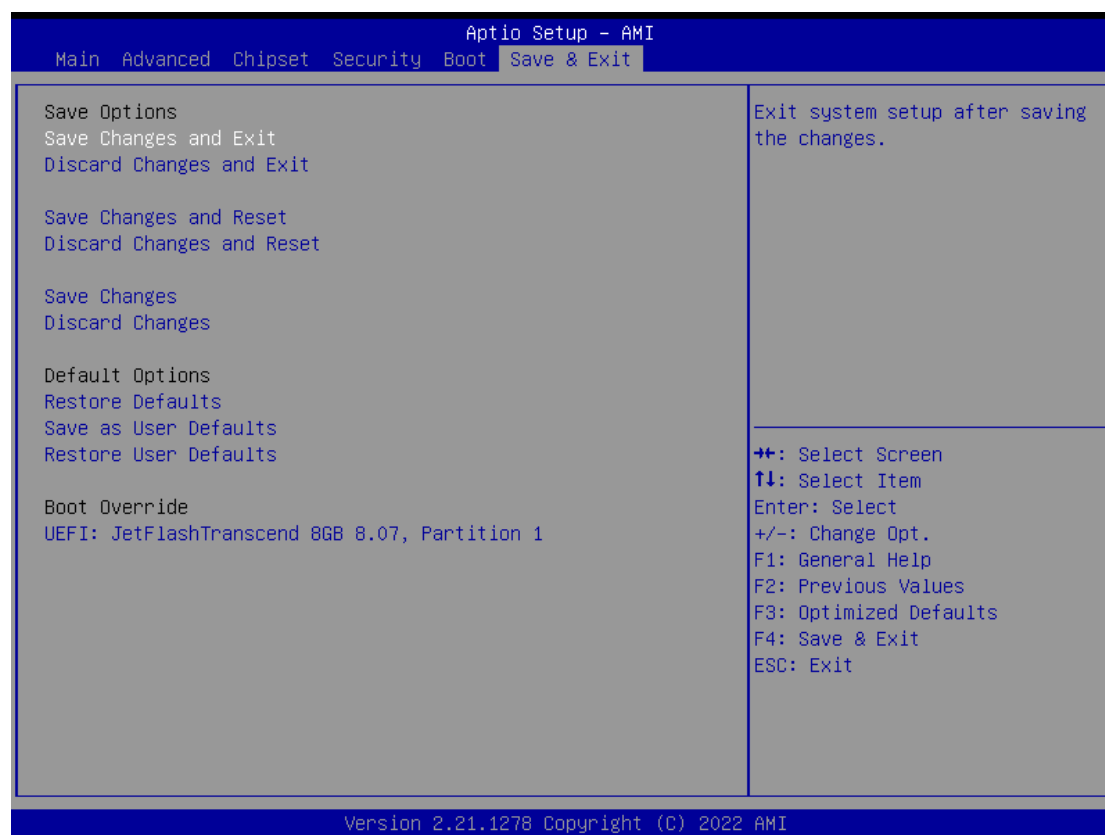

Save Changes and Exit

When users have completed the system configuration changes, select this option to leave Setup and return to Main Menu. Select Save Changes and Exit from the Save & Exit menu and press <Enter>. Select Yes to save changes and exit.

Discard Changes and Exit

Select this option to quit Setup without making any permanent changes to the system configurations and return to Main Menu. Select Discard Changes and Exit from the Save & Exit menu and press <Enter>. Select Yes to discard changes and exit.

Save Changes and Reset

Having completed the system configuration changes, select this option to leave Setup and reboot the computer so the new system configurations take effect. Select Save Changes and Reset from the Save & Exit menu and press <Enter>. Select Yes to save changes and reset.

Discard Changes and Reset

Select this option to quit Setup without making any permanent changes to the system configuration and reboot the computer. Select Discard Changes and Reset from the Save & Exit menu and press <Enter>. Select Yes to discard changes and reset.

Save Changes

Having completed the system configuration changes, select this option to save changes. Select Save Changes from the Save & Exit menu and press <Enter>. Select Yes to save changes.

Discard Changes

Select this option to quit Setup without making any permanent changes to the system configurations. Select Discard Changes from the Save & Exit menu and press <Enter>. Select Yes to discard changes.

Restore Defaults

It automatically sets all Setup options to a complete set of default settings when users select this option. Select Restore Defaults from the Save & Exit menu and press <Enter>.

Save as User Defaults

Select this option to save system configuration changes done so far as User Defaults. Select Save as User Defaults from the Save & Exit menu and press <Enter>.

Restore User Defaults

It automatically sets all Setup options to a complete set of User Defaults when users select this option. Select Restore User Defaults from the Save & Exit menu and press <Enter>.

Boot Override

Select a drive to immediately boot that device regardless of the current boot order.

APPENDIX A WATCHDOG TIMER

A.1 About Watchdog Timer

Software stability is major issue in most application. Some embedded systems are not watched by human for 24 hours. It is usually too slow to wait for someone to reboot when computer hangs. The systems need to be able to reset automatically when things go wrong. The watchdog timer gives us solution.

The watchdog timer is a counter that triggers a system reset when it counts down to zero from a preset value. The software starts counter with an initial value and must reset it periodically. If the counter ever reaches zero which means the software has crashed, the system will reboot.

A.2 Sample Program

```
#include "stdafx.h"
#include <windows.h>
#include <stdio.h>
#include <tchar.h>
#include <stdlib.h>

#ifdef _DEBUG
#define new DEBUG_NEW
#endif

#pragma comment (lib, "User32.lib" )

#define IDT_TIMER WM_USER + 200
#define _CRT_SECURE_NO_WARNINGS 1
#define setbit(value,x) (value |= (1<<x))
#define clrbit(value,x) (value &= ~(1<<x))

HINSTANCE hinstLibDLL = NULL;
```

```
LONG WDTDATA = 0;

typedef ULONG(*LPFNDDLGETIOSPACE)(ULONG);
LPFNDDLGETIOSPACE lpFnDII_Get_IO;
typedef void(*LPFNDDLSETIOSPACE)(ULONG, ULONG);
LPFNDDLSETIOSPACE lpFnDII_Set_IO;

int _tmain(int argc, _TCHAR* argv[])
{
    int unit = 0;
    int WDTtimer = 0;
    if (hinstLibDLL == NULL)
    {
        hinstLibDLL = LoadLibrary(TEXT("diodll.dll"));
        if (hinstLibDLL == NULL)
        {
            //MessageBox("Load diodll dll error", "", MB_OK);
        }
    }

    if (hinstLibDLL)
    {
        lpFnDII_Get_IO = (LPFNDDLGETIOSPACE)GetProcAddress(GetModuleHandle("diodll.dll"),
            "GetIoSpaceByte");
        lpFnDII_Set_IO = (LPFNDDLSETIOSPACE)GetProcAddress(GetModuleHandle("diodll.dll"),
            "SetIoSpaceByte");
    }

    printf("Input Watch Dog Timer type, 1:Second ; 2:Minute :");
    scanf("%d",&unit);
    printf("\nInput Timer to countdown:");
    scanf("%d", &WDTtimer);
    printf("Start to countdown...");

    //==Enter MB Pnp Mode==
    lpFnDII_Set_IO(0x2e, 0x87);
    lpFnDII_Set_IO(0x2e, 0x87);
    lpFnDII_Set_IO(0x2e, 0x07);
    lpFnDII_Set_IO(0x2f, 0x07); //SET LDN 07
```

```
//set LDN07 FA 10 to 11
lpFnDII_Set_IO(0x2e, 0xFA);
WDTDATA = lpFnDII_Get_IO(0x2f);
WDTDATA = setbit(WDTDATA, 0);
lpFnDII_Set_IO(0x2f, WDTDATA);
if (unit == 1)
{
lpFnDII_Set_IO(0x2e, 0xF6);
lpFnDII_Set_IO(0x2f, WDTtimer);

//start watchdog counting
lpFnDII_Set_IO(0x2e, 0xF5);
WDTDATA = lpFnDII_Get_IO(0x2f);
WDTDATA = setbit(WDTDATA, 5);
lpFnDII_Set_IO(0x2f, WDTDATA);
}
else if (unit == 2)
{
//set WDT Timer
lpFnDII_Set_IO(0x2e, 0xF6);
lpFnDII_Set_IO(0x2f, WDTtimer);
//set watchdog time unit to min
lpFnDII_Set_IO(0x2e, 0xF5);
WDTDATA = lpFnDII_Get_IO(0x2f);
WDTDATA = setbit(WDTDATA, 3);
lpFnDII_Set_IO(0x2f, WDTDATA);
//start watchdog counting
lpFnDII_Set_IO(0x2e, 0xF5);
WDTDATA = lpFnDII_Get_IO(0x2f);
WDTDATA = setbit(WDTDATA, 5);
lpFnDII_Set_IO(0x2f, WDTDATA);
}
system("pause");
return 0;
}
```

This page is intentionally left blank